

▲ double bay style walk-in

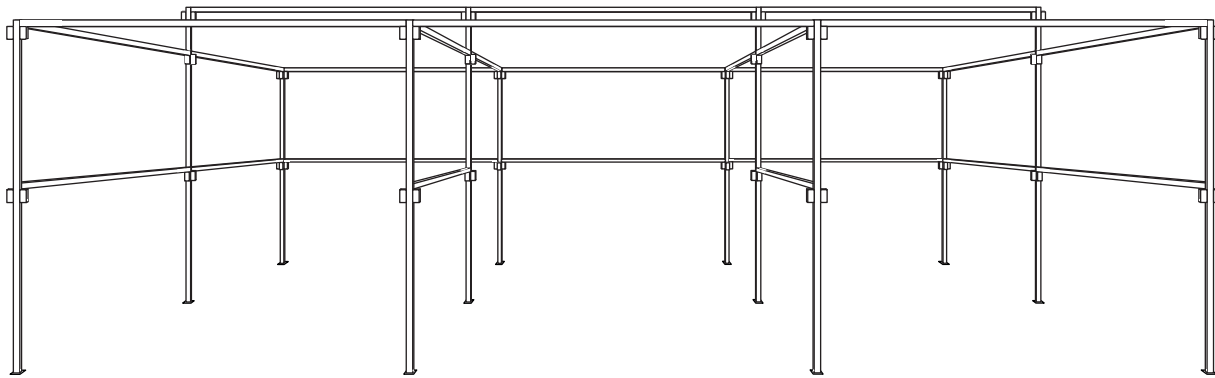

▲ triple bay style walk-in

further details overleaf

LARGE WALK-IN STALLS

20' x 10', 16' x 16', 24' x 16', 20' x 20', 30' x 20', 32' x 16' and 40' x 20'

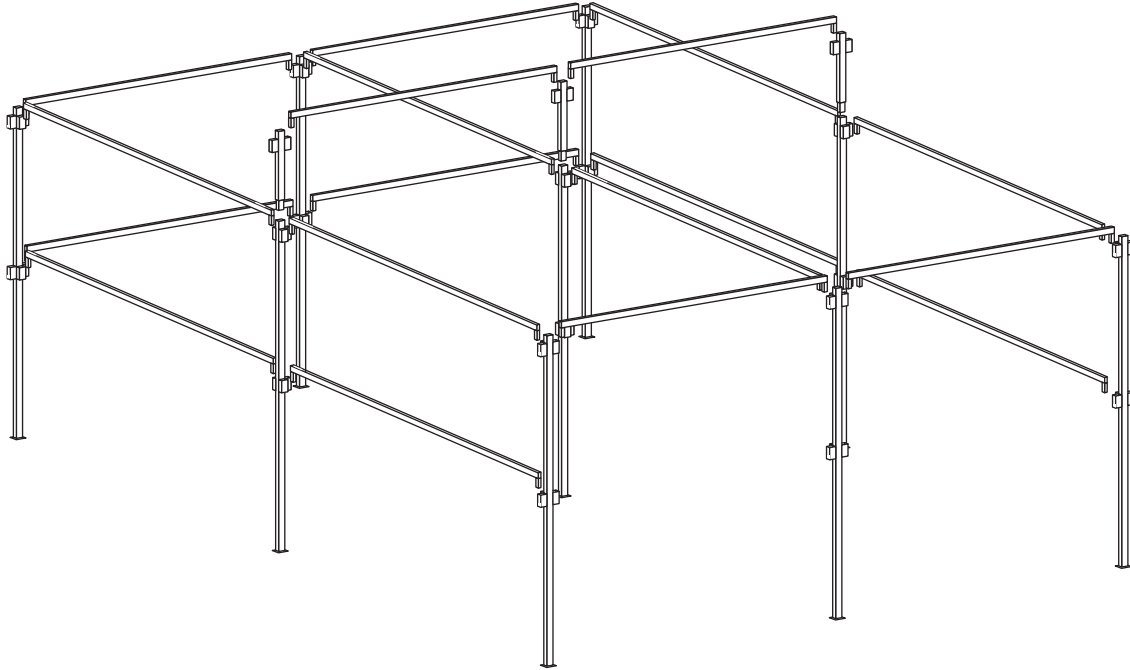

SPECIFICATIONS

	# OF PARTS	WEIGHT STEEL ONLY / STARTER KIT	COVERS TO SUIT	MAX. LENGTH
20' x 10'	22	80kg / 90kg	1 off 23' x 18' (to cover top and back) 2 off 12' x 9' (to cover sides)	10'
16' x 16'	30	104kg / 109kg	1 off 23' x 18' (to cover top and back) 1 off 20' x 15' cut in half (to cover sides)	8.0'
20' x 20'	30	121kg / 126kg	1 off 29' x 23' (to cover top and back) 1 off 23' x 18' cut in half (to cover sides)	10'
24' x 16'	40	138kg / 146kg	1 off 29' x 23' (to cover top and back) 1 off 20' x 15' cut in half (to cover sides)	8.0'
30' x 20'	40	162kg / 177kg	1 off 35' x 23' (to cover top) 1 off 29' x 23' cut in thirds (to cover sides and back)	10'
32' x 16'	50	173kg / 183kg	1 off 35' x 25' (to cover top) 1 off 29' x 23' cut in thirds (to cover sides and back)	8.0'
40' x 20'	50	203kg / 228kg	1 off 45' x 29' (to cover top and back) 1 off 23' x 18' cut in half (to cover sides)	10'

All stalls are manufactured using 1" x 1" square mild steel and painted in a black hammer finish gloss.
Stalls can be purchased as complete starter kits (steelwork, covers and clips) or as steelwork only.
We can manufacture stalls to your specification, please call with your requirements.

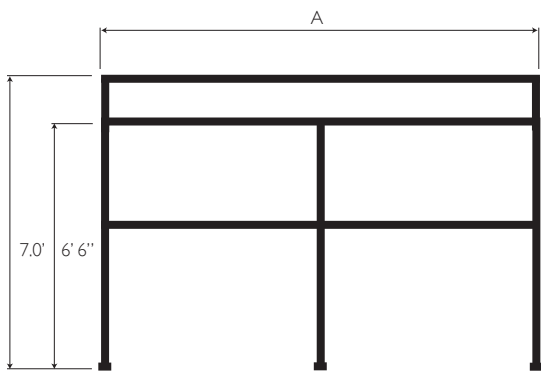

front view

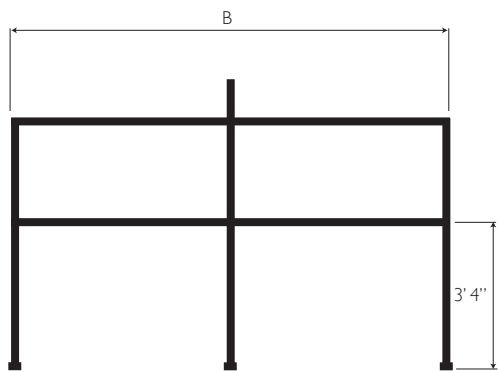

side view

	A	B
20' x 10'	20'	10'
16' x 16'	16'	16'
20' x 20'	20'	20'
24' x 16'	24'	16'
30' x 20'	30'	20'
32' x 16'	32'	16'
40' x 20'	40'	20'