

further details overleaf

WALK-IN STALLS WITH FRONT COUNTERS

8' x 8', 10' x 8', 12' x 8'

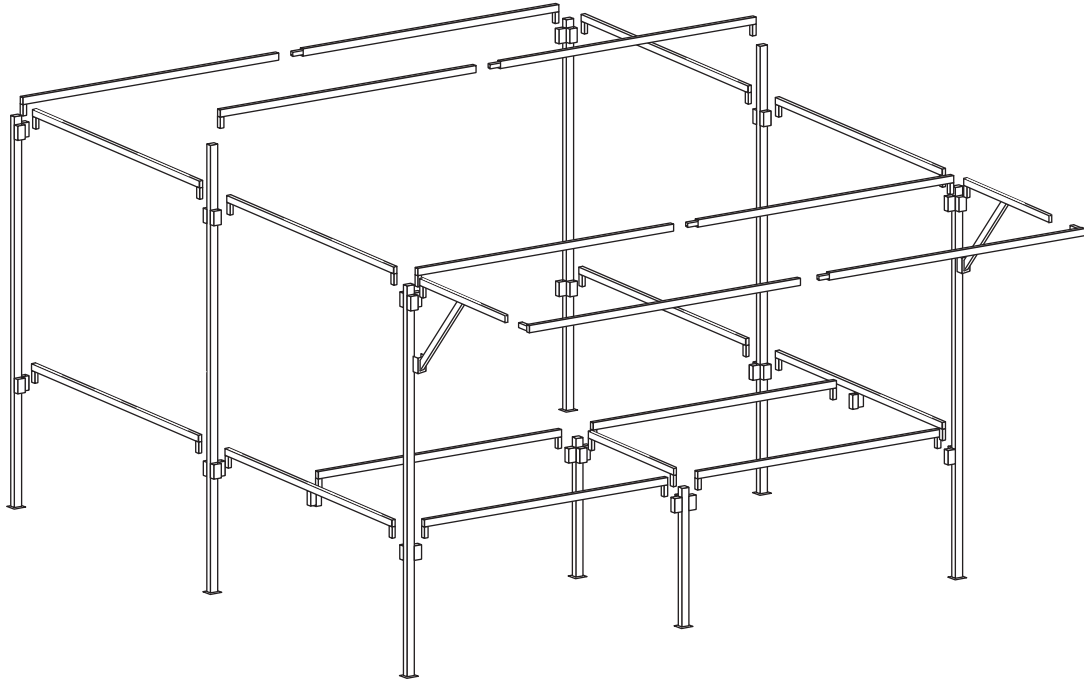

SPECIFICATIONS

	# OF PARTS	WEIGHT STEEL ONLY / STARTER KIT	COVERS TO SUIT	COUNTERS TO SUIT	MAX. LENGTH
8' x 8'	31	67kg / 74kg	1 off 12' x 18' (to cover top and back) 2 off 12' x 9' (to cover sides)	2 off 4' x 2'	7.0'
10' x 10'	31	74kg / 82kg	1 off 12' x 18' (to cover top and back) 2 off 12' x 9' (to cover sides)	2 off 4' x 2' 1 off 2' x 2'	7.0'
12' x 10'	31	80kg / 90kg	1 off 20' x 15' (to cover top and back) 2 off 12' x 9' (to cover sides)	3 off 4' x 2'	7.0'

All stalls are manufactured using 1" x 1" square mild steel and painted in a black hammer finish gloss.
Stalls can be purchased as complete starter kits (steelwork, counters, covers and clips) or as steelwork only.
We can manufacture stalls to your specification, please call with your requirements.

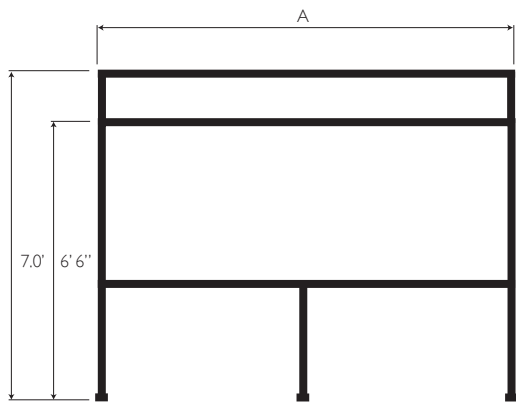

front view

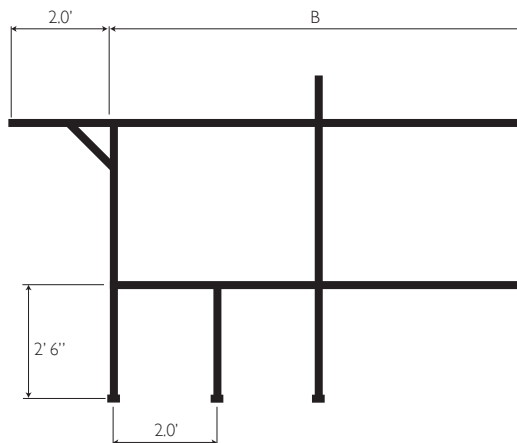

side view

	A	B
8' x 8'	8'	8'
10' x 8'	10'	8'
12' x 8'	12'	8'