

## No one quite understands market stalls like we do.

We have been building market stalls since May, 1974. The majority of our stalls are manufactured for individual traders whose requirements are as different from one another as the products they sell.

In this brochure you will find our standard range of stalls which are a good starting point when considering how to display and sell your products. You may, however require something a little different, in which case our 30 years of experience is at your disposal if you wish to discuss your ideas with us over the phone or via the internet.

A few practical thoughts may help you along the way; Stalls need to be **strong** and **sturdy** but not too heavy, and they need to be able to withstand rough treatment during transportation and erection. **Simplicity** is always key. Erecting a stall on a cold, dark February morning is made a lot easier and quicker if the design is kept simple by using as few parts as possible.

As you'll see throughout this brochure, we try to manufacture our stalls and accessories to fit these requirements, but the overriding factor is, *will it sell your product?* Display counts for a great deal and should be forefront in your mind when making any decisions about your stall. Make your product look good - consider how you can display and sell it to your best advantage. A good tip is to look to how others do it, not just other market traders, but also high street stores and supermarkets. Don't be afraid to borrow their ideas and mould them around your own requirements keeping in mind **strength, practicality** and **simplicity**.

We're more than happy to discuss ideas with you and can help turn a raw idea into a practical design, so please, get in touch.



Gavin Kenning

## CONTENTS

### ▶ TRADITIONAL STALLS

Standard Traditional Stalls.....	3-4
Basic Traditional Stalls.....	5-6
Mini Parts Traditional Stalls.....	7-10

### ▶ SPECIAL PURPOSE STALLS

Flower Stalls.....	11-12
Food Stalls.....	13-14
Demonstrator Stalls.....	15-16
Fashion Stalls.....	17-18

### ▶ WALK-IN STALLS

General Purpose Walk-in Stalls.....	19-20
Large Walk-in Stalls.....	21-22
Walk-in Stalls with counters.....	23-24
Walk-in Stalls with rear counters.....	25-26
Walk-in Stalls with front counters.....	27-28

### ▶ MARKET STALL EQUIPMENT

Dress Rails.....	29-30
Tables.....	31-32
Step Displays.....	33-34
Sofa Display Stands.....	35-36
Hanger Brackets.....	37
Clips.....	38
Further Information.....	39
How to find us / contact details.....	40

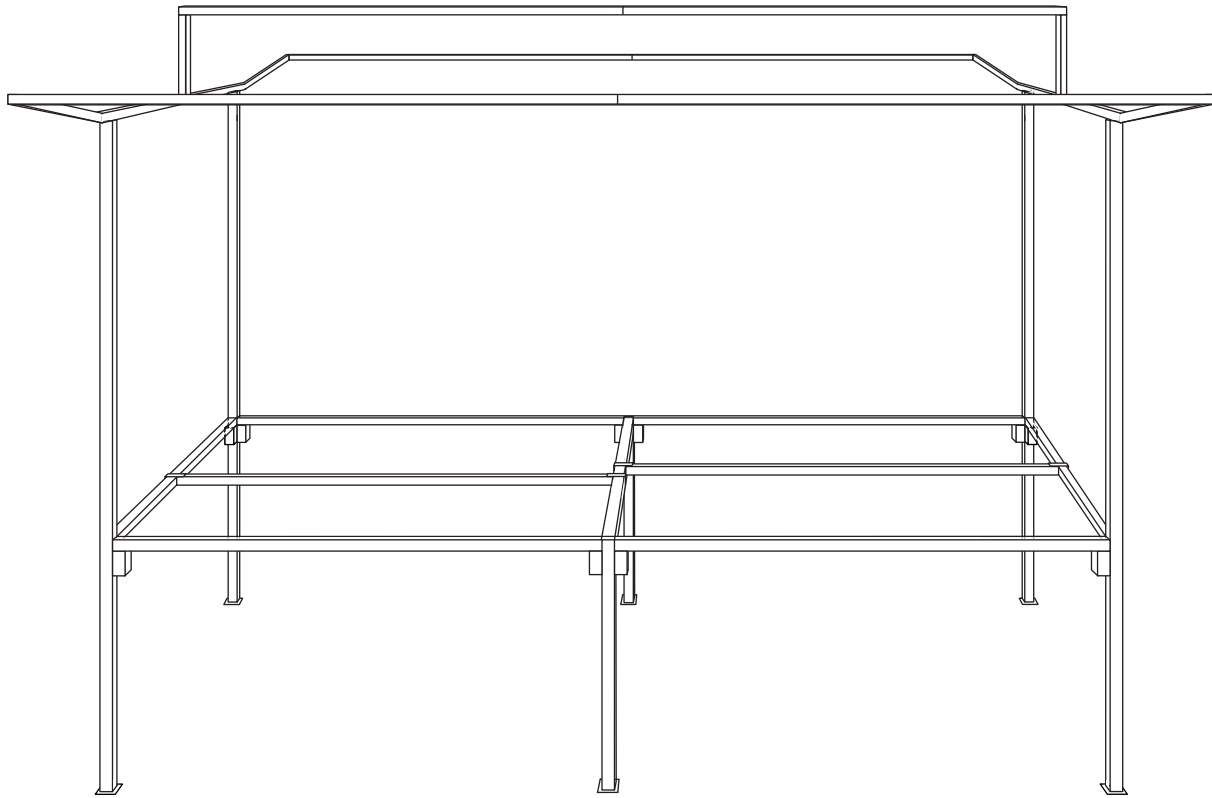
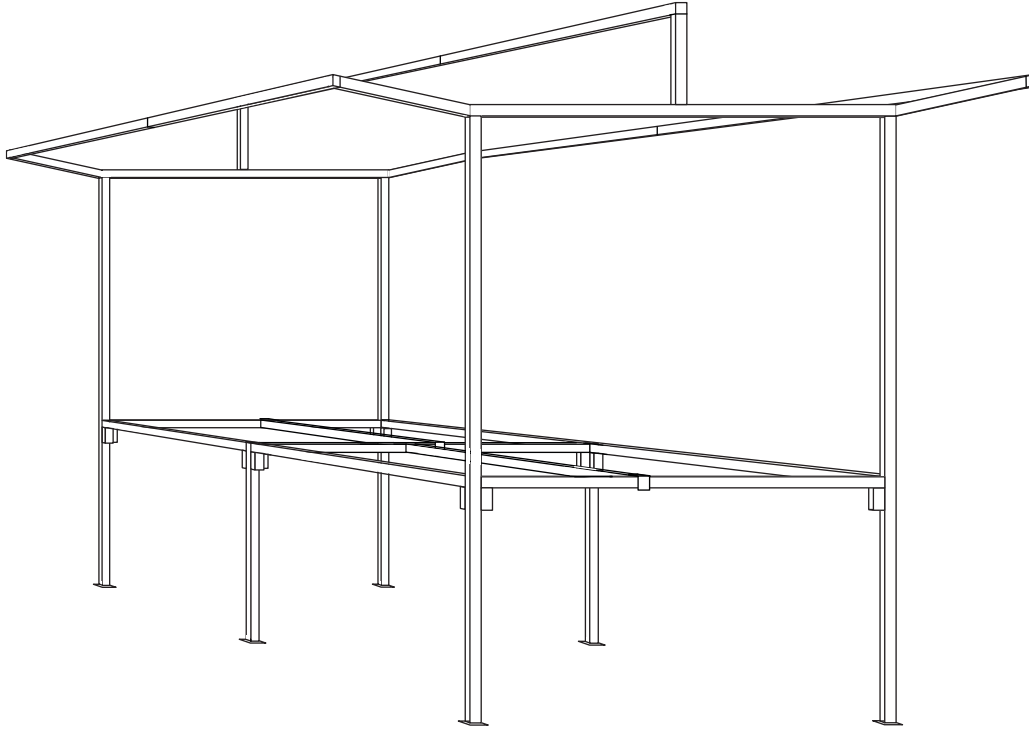

further details overleaf

# STANDARD TRADITIONAL STALLS

8' x 4', 10' x 4', 12' x 4' and 14' x 4'

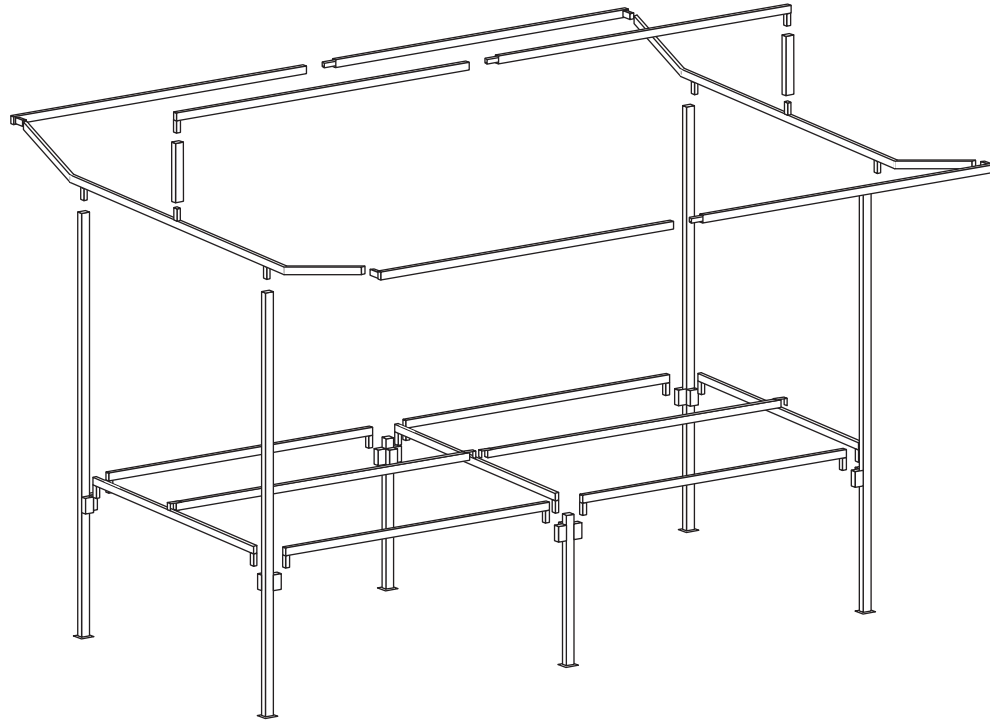

## SPECIFICATIONS

	# OF PARTS	WEIGHT STEEL ONLY / STARTER KIT	COVERS TO SUIT	COUNTERS TO SUIT	MAX. LENGTH
<b>8' x 4'*</b>	25	53kg / 66kg	12' x 18' (to cover top and back)	4 off 4' x 2' boards	7.0'
<b>10' x 4'</b>	25	59kg / 76kg	12' x 18' (to cover top and back)	5 off 4' x 2' boards	7.0'
<b>12' x 4'</b>	25	65kg / 85kg	20' x 15' (to cover top and back)	6 off 4' x 2' boards	7.0'
<b>14' x 4'</b>	25	71kg / 94kg	20' x 15' (to cover top and back)	7 off 4' x 2' boards	7' 4.25"

All stalls are manufactured using 1" x 1" square mild steel and painted in a black hammer finish gloss. Stalls can be purchased as complete starter kits (steelwork, counter, cover and clips) or as steelwork only. We can manufacture stalls to your specification, please call with your requirements.

\* 8' x 4' shown here offers an alternative to the Basic 8' x 4' with a shorter maximum length of 7.0'.

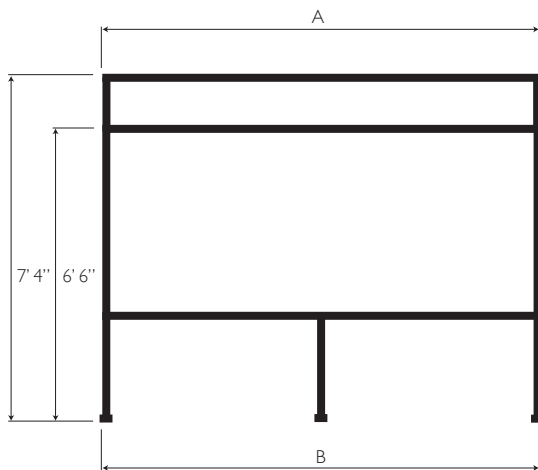

front view

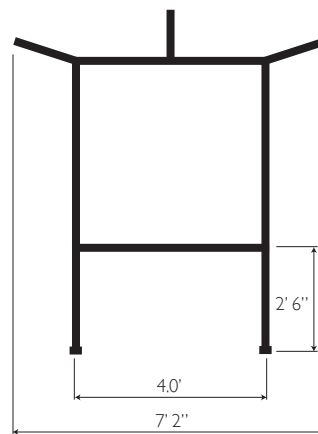

side view

	A	B
8' x 4'	8' 0.5"	8'
10' x 4'	10' 0.5"	10'
12' x 4'	12' 0.5"	12'
14' x 4'	14' 0.5"	14'

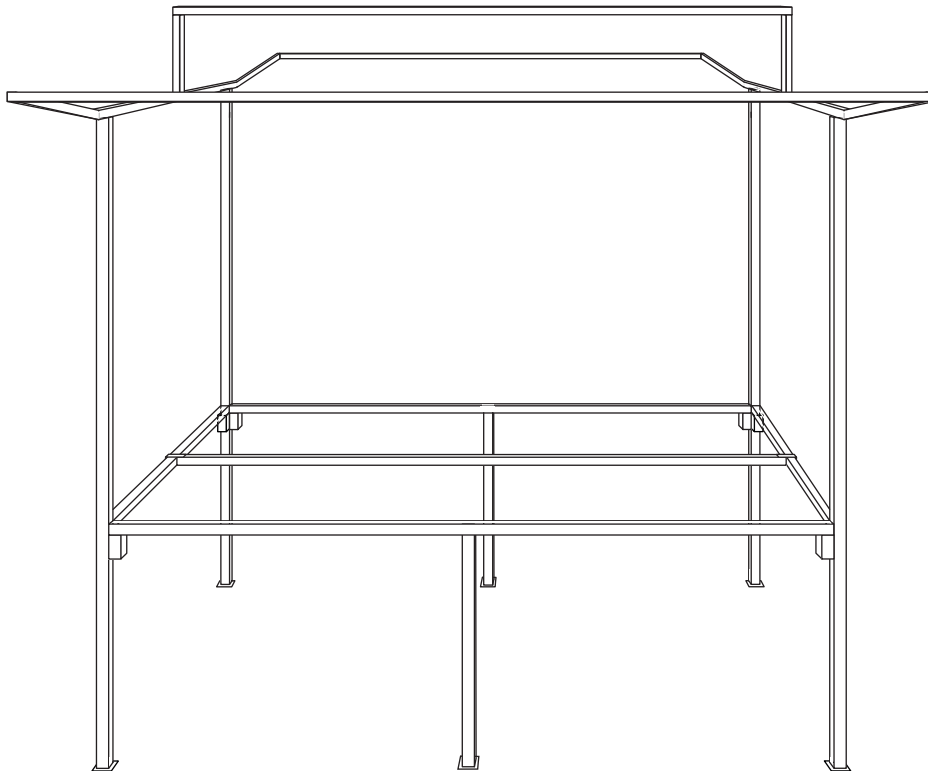
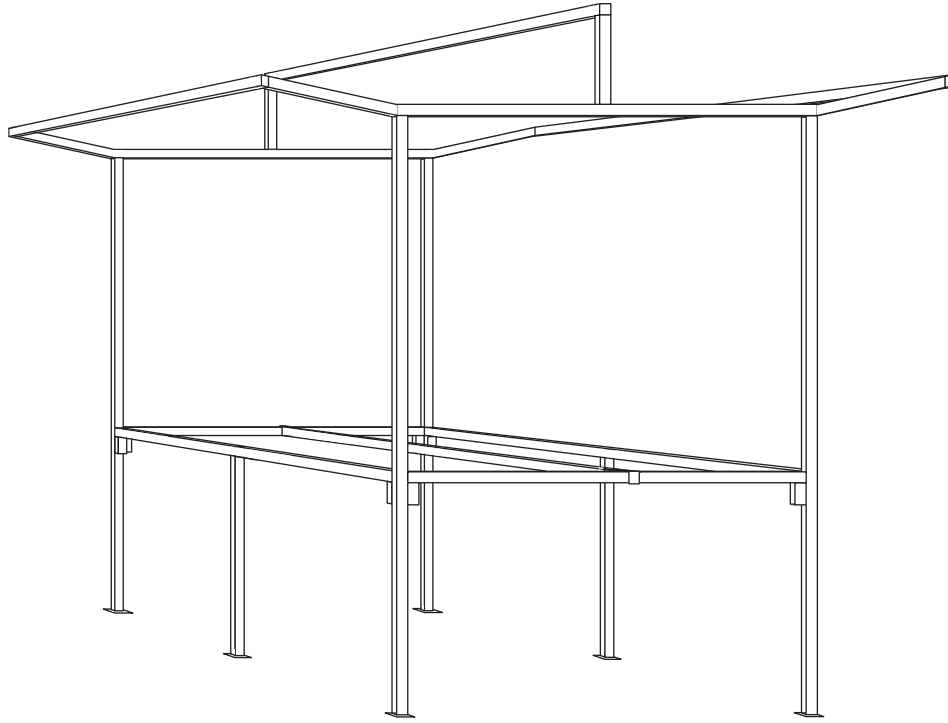

further details overleaf

# BASIC TRADITIONAL STALLS

6' x 4' and 8' x 4'

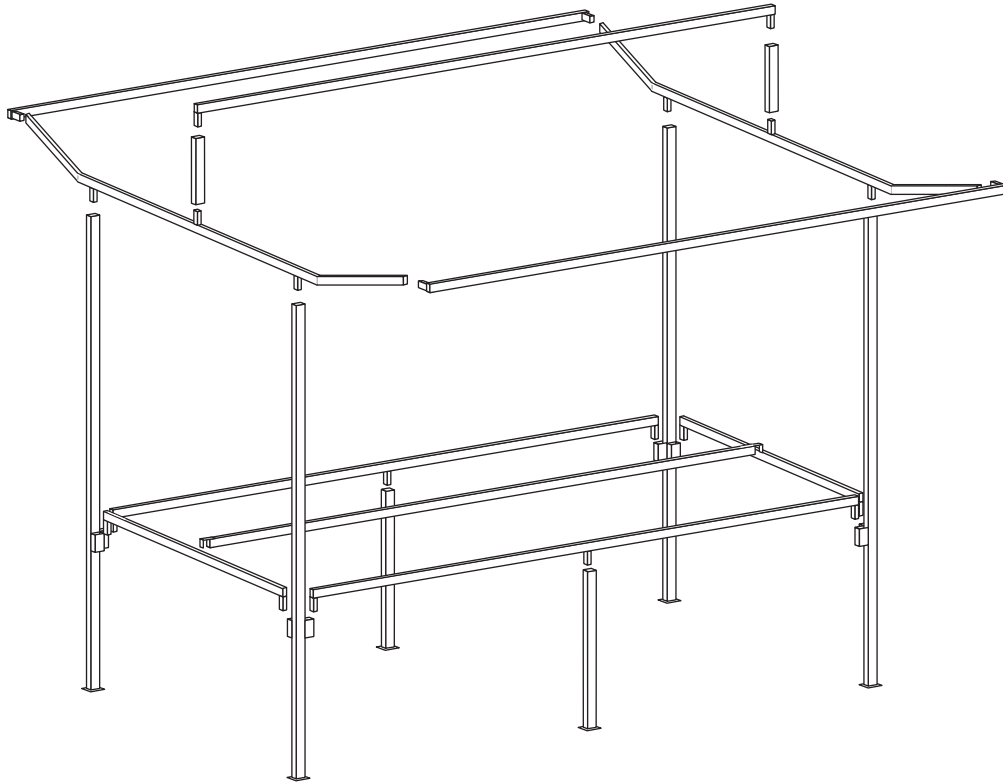

## SPECIFICATIONS

	# OF PARTS	WEIGHT STEEL ONLY / STARTER KIT	COVERS TO SUIT	COUNTERS TO SUIT	MAX. LENGTH
6' x 4'	16	44kg / 54kg	12' x 18' (to cover top and back)	3 off 4' x 2' boards	7.0'
8' x 4'	17	50kg / 63kg	12' x 18' (to cover top and back)	4 off 4' x 2' boards	8' 0.5"

All stalls are manufactured using 1" x 1" square mild steel and painted in a black hammer finish gloss.  
 Stalls can be purchased as complete starter kits (steelwork, counter, cover and clips) or as steelwork only.  
 We can manufacture stalls to your specification, please call with your requirements.

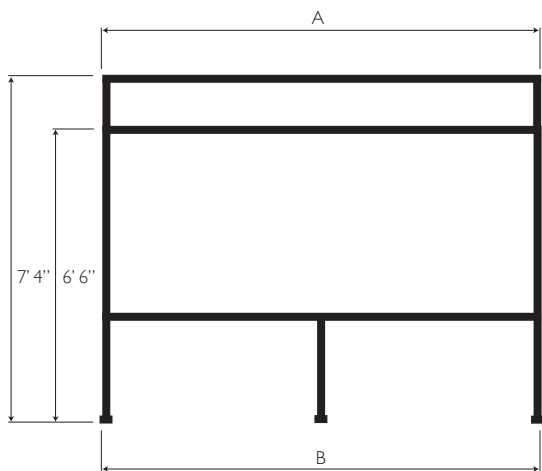

front view

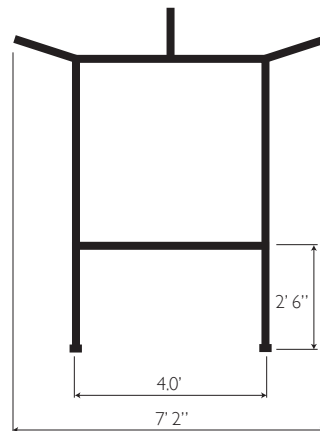

side view

	A	B
6' x 10'	6' 0.5"	6'
8' x 10'	8' 0.5"	8'

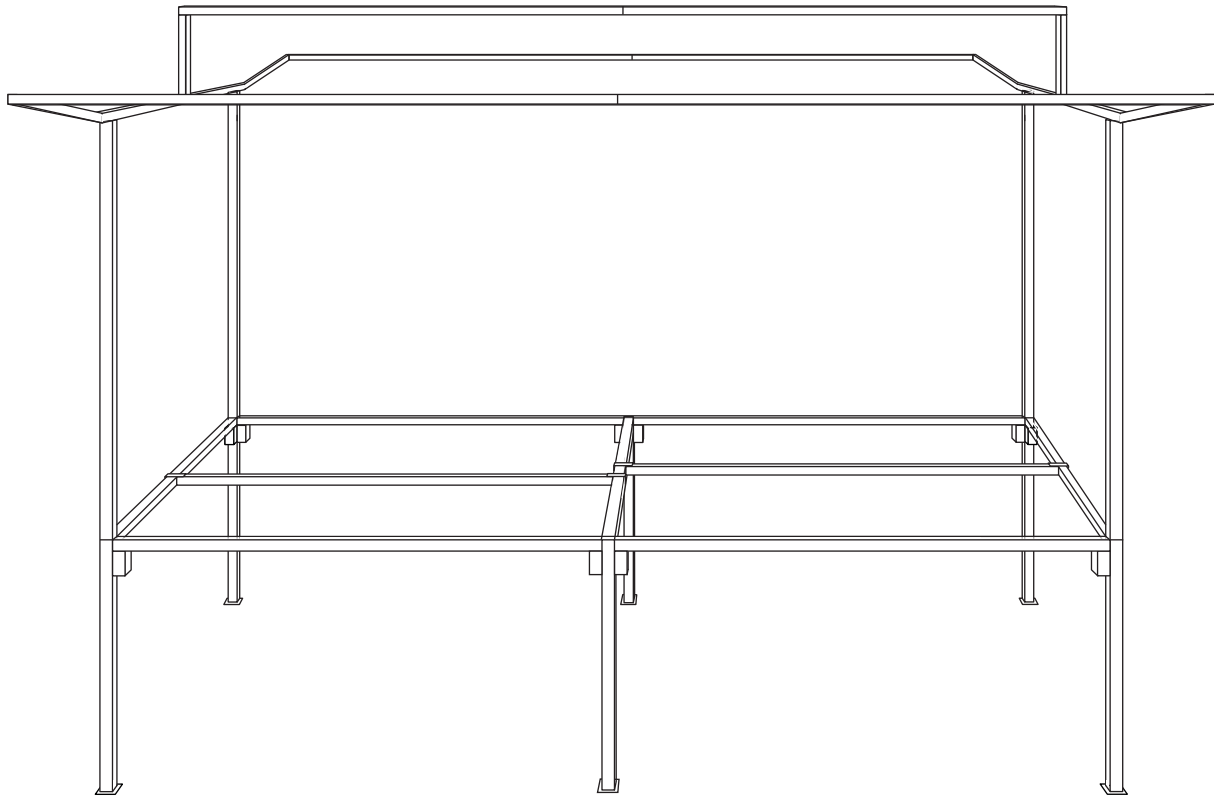
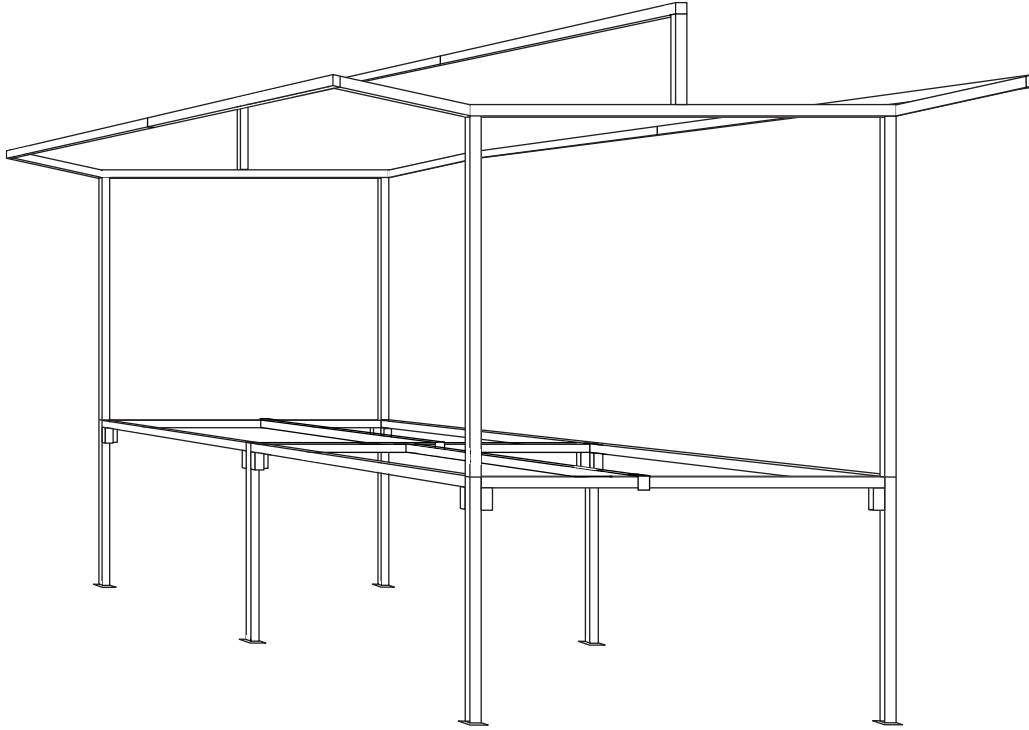

further details overleaf

# SMALL MINI PARTS TRADITIONAL STALLS

6' x 4' and 8' x 4'

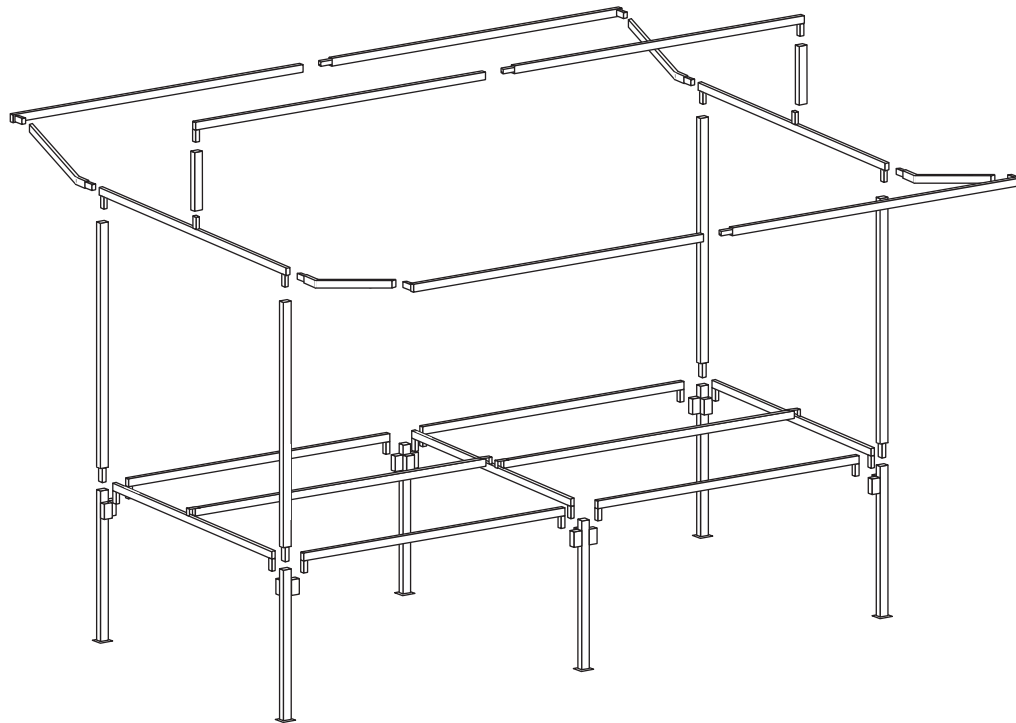

## SPECIFICATIONS

	# OF PARTS	WEIGHT STEEL ONLY / STARTER KIT	COVERS TO SUIT	COUNTERS TO SUIT	MAX. LENGTH
6' x 4'	31	54kg / 66kg	12' x 18' (to cover top and back)	3 off 4' x 2' boards	4' 0.25"
8' x 4'	31	60kg / 74kg	12' x 18' (to cover top and back)	4 off 4' x 2' boards	4' 4.25"

All stalls are manufactured using 1" x 1" square mild steel and painted in a black hammer finish gloss.  
 Stalls can be purchased as complete starter kits (steelwork, counter, cover and clips) or as steelwork only.  
 We can manufacture stalls to your specification, please call with your requirements.

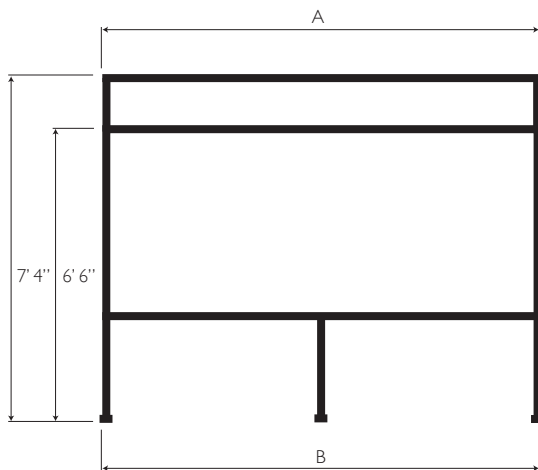

front view

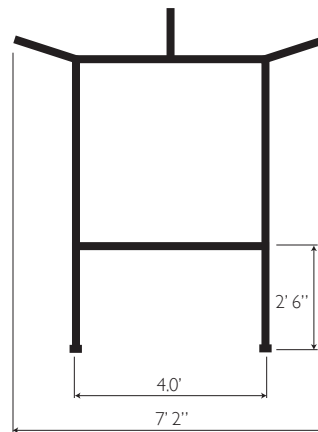

side view

	A	B
6' x 4'	5' 0.5"	6'
8' x 4'	8' 0.5"	8'

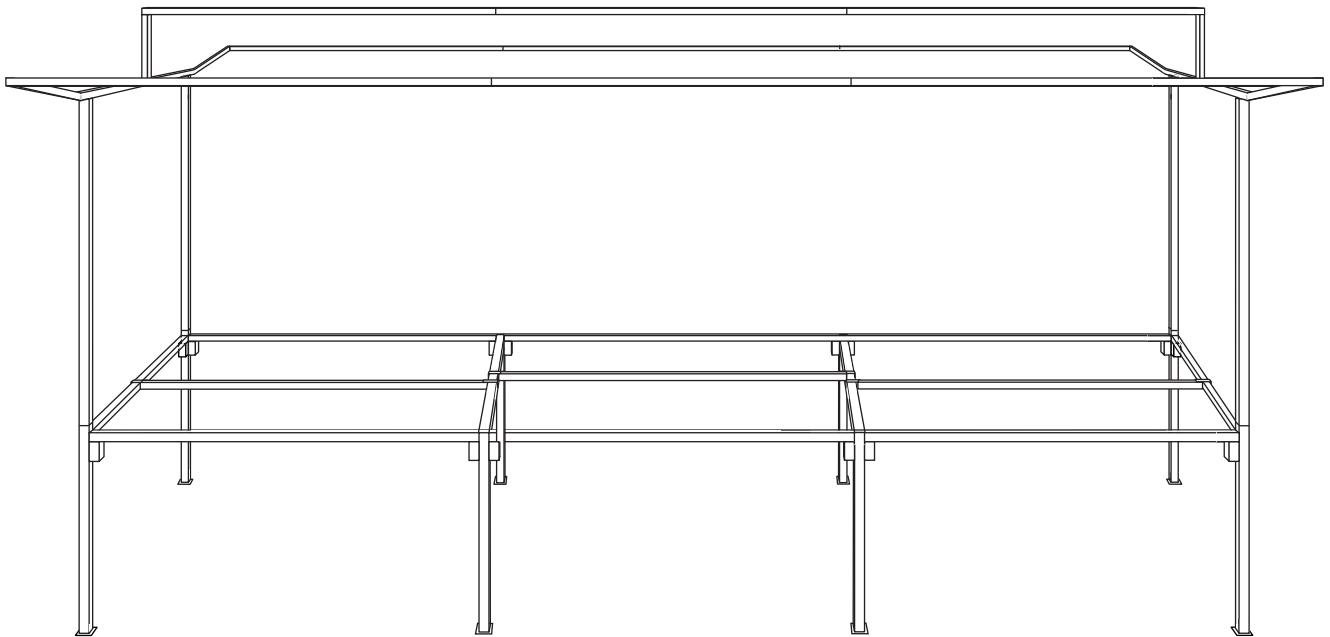
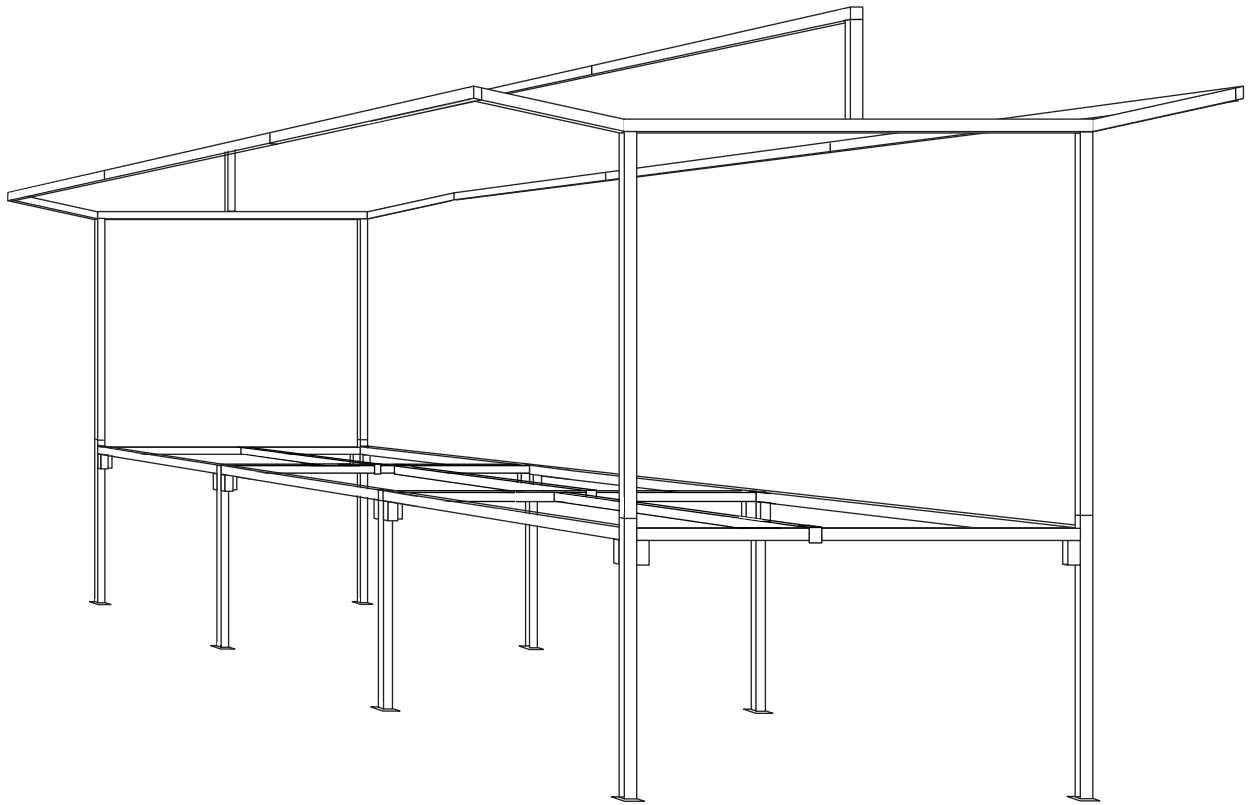

further details overleaf

# LARGE MINI PARTS TRADITIONAL STALLS

10' x 4' and 12' x 4'

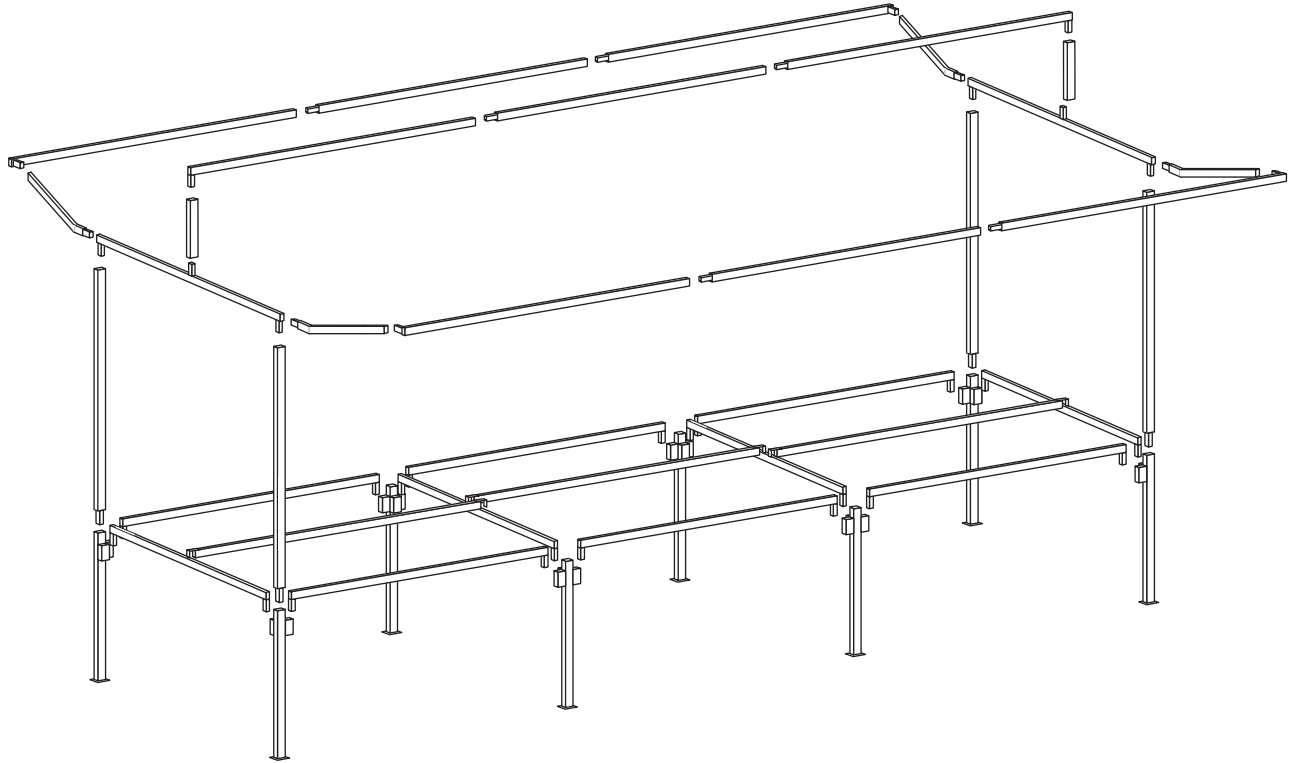

## SPECIFICATIONS

	# OF PARTS	WEIGHT STEEL ONLY / STARTER KIT	COVERS TO SUIT	COUNTERS TO SUIT	MAX. LENGTH
10' x 4'	40	66kg / 83kg	12' x 18' (to cover top and back)	5 off 4' x 2' boards	4' 4.25"
12' x 4'	40	70kg / 90kg	20' x 15' (to cover top and back)	6 off 4' x 2' boards	4' 4.25"

All stalls are manufactured using 1" x 1" square mild steel and painted in a black hammer finish gloss.  
 Stalls can be purchased as complete starter kits (steelwork, counter, cover and clips) or as steelwork only.  
 We can manufacture stalls to your specification, please call with your requirements.

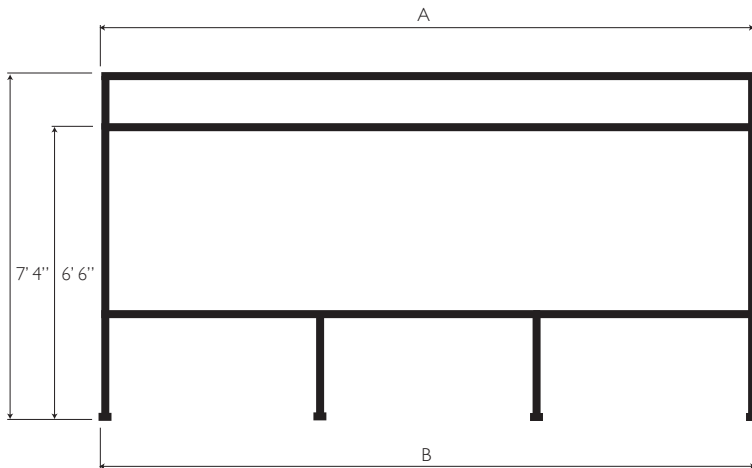

front view

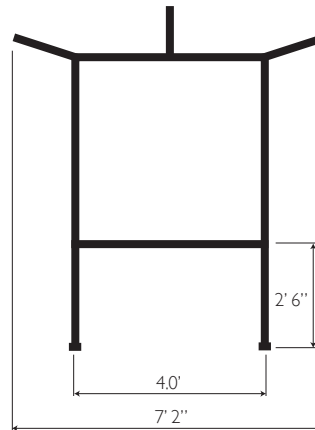

side view

	A	B
10' x 4'	10' 0.5"	10'
12' x 4'	12' 0.5"	12'

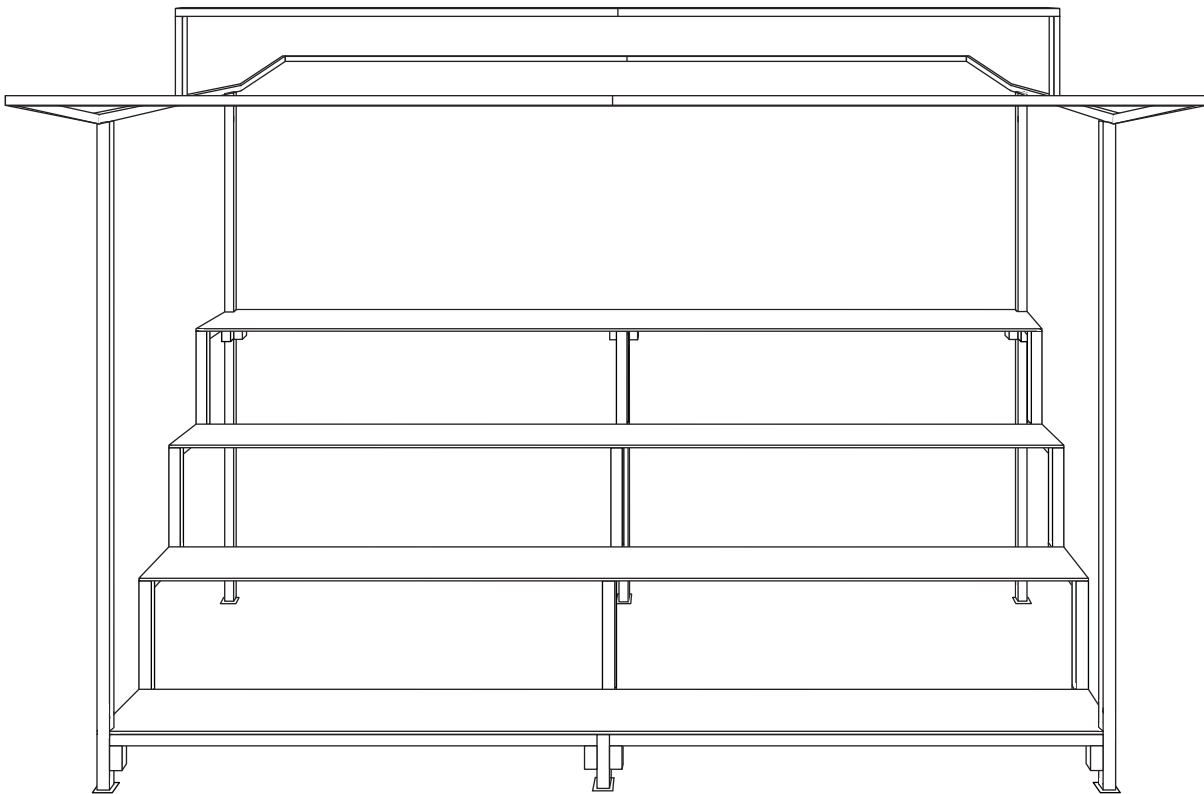
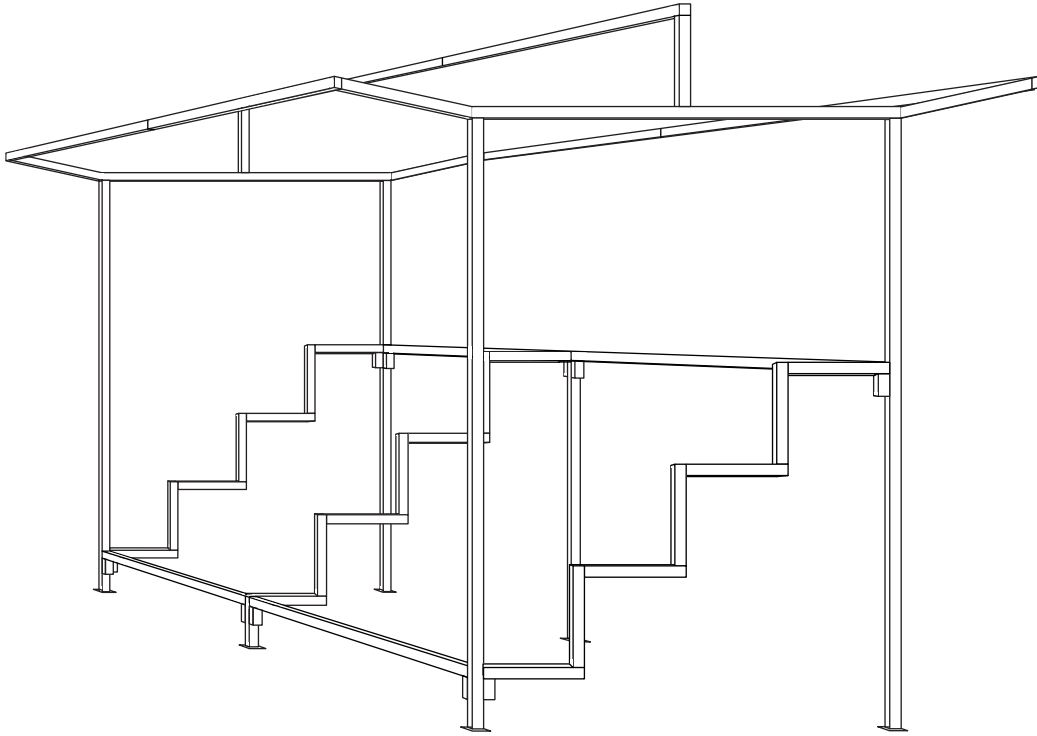

further details overleaf

# FLOWER STALLS

6' x 4', 8' x 4' and 10' x 4'

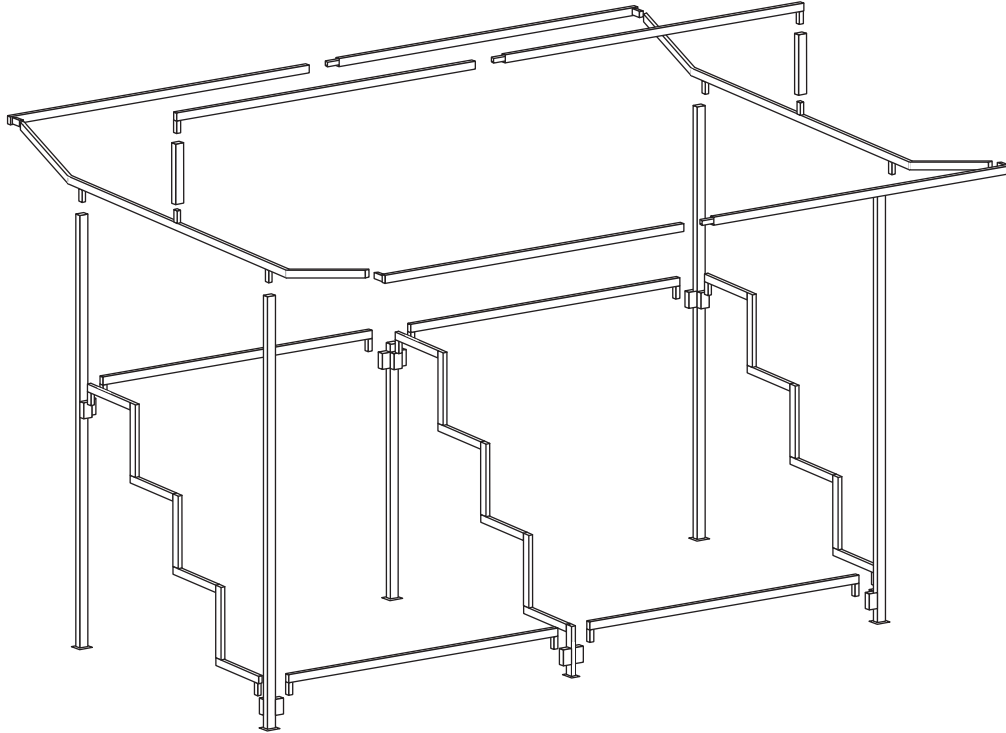

## SPECIFICATIONS

	# OF PARTS	WEIGHT STEEL ONLY / STARTER KIT	COVERS TO SUIT	COUNTERS TO SUIT	MAX. LENGTH
<b>6' x 4'</b>	15	46kg / 56kg	12' x 18' (to cover top and back)	4 off 6' x 1' boards	7.0' (may be reduced)
<b>8' x 4'</b>	21	51kg / 64kg	12' x 18' (to cover top and back)	8 off 4' x 1' boards	7.0' (may be reduced)
<b>10' x 4'</b>	21	56kg / 73kg	12' x 18' (to cover top and back)	8 off 5' x 1' boards	7.0' (may be reduced)

All stalls are manufactured using 1" x 1" square mild steel and painted in a black hammer finish gloss. Stalls can be purchased as complete starter kits (steelwork, counter, cover and clips) or as steelwork only. We can manufacture stalls to your specification, please call with your requirements.

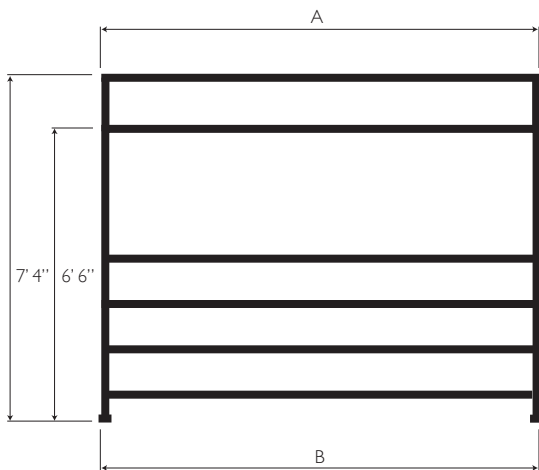

front view

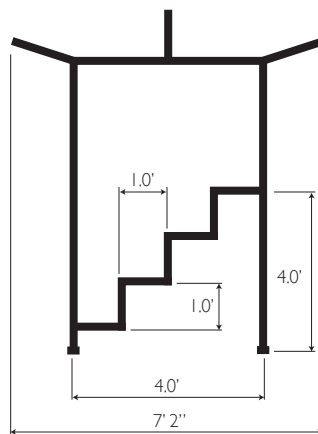

side view

	A	B
<b>6' x 4'</b>	6' 0.5"	6'
<b>8' x 4'</b>	8' 0.5"	8'
<b>10' x 4'</b>	10' 0.5"	10'

291207

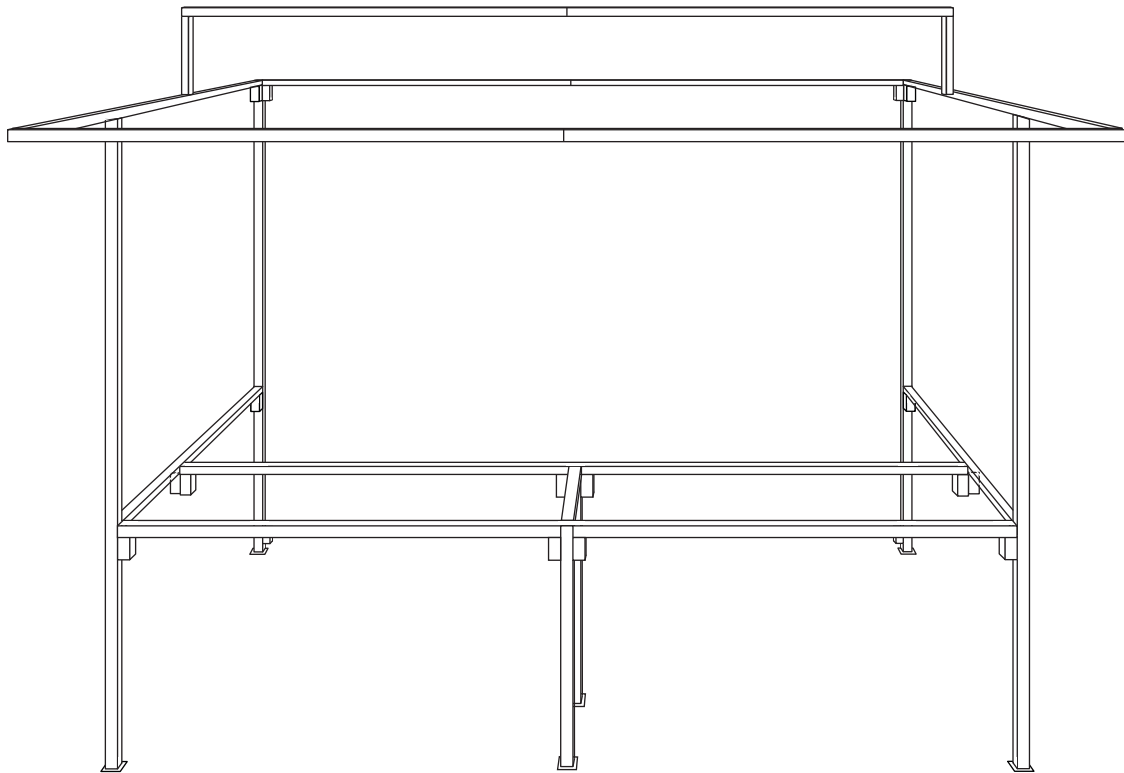
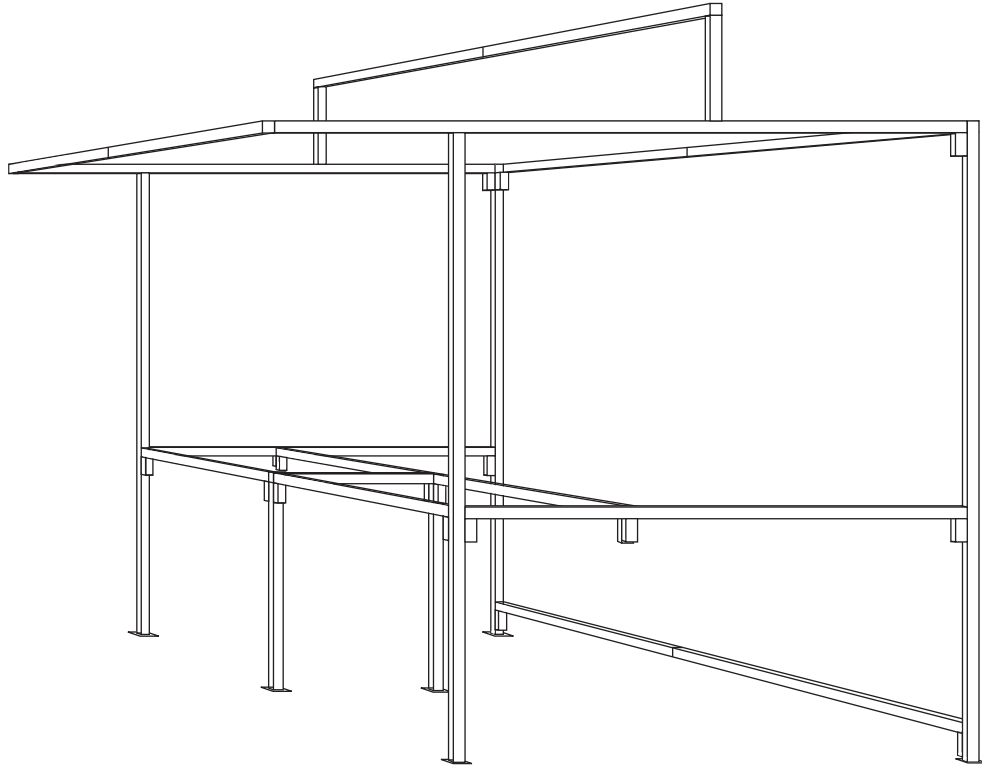

further details overleaf

# FOOD STALLS

6' x 6', 8' x 6' and 10' x 6'

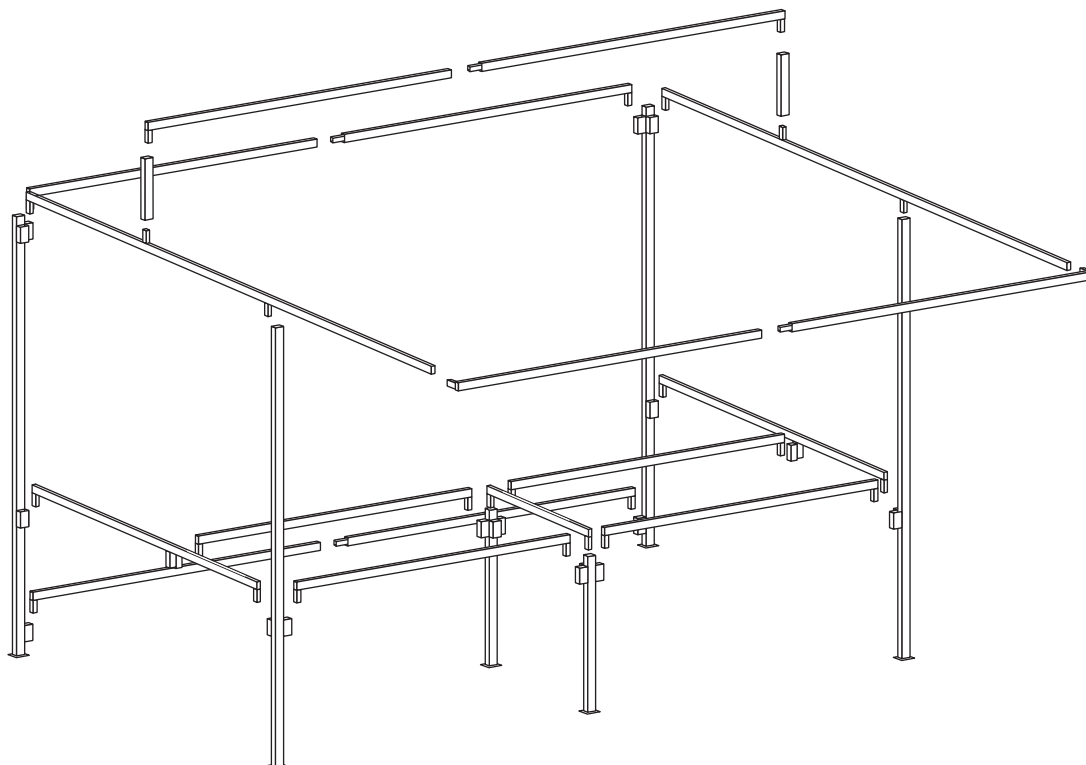

## SPECIFICATIONS

	# OF PARTS	WEIGHT STEEL ONLY / STARTER KIT	COVERS TO SUIT	COUNTERS TO SUIT	MAX. LENGTH
6' x 6'	16	50kg / 56kg	12' x 18' (to cover top and back)	2 off 3' x 2' boards	7' 6"
8' x 6'	25	56kg / 63kg	12' x 18' (to cover top and back)	2 off 4' x 2' boards	7' 6"
10' x 6'	25	62kg / 71kg	12' x 18' (to cover top and back)	2 off 4' x 2' boards 1 off 2' x 2' board	7' 6"

All stalls are manufactured using 1" x 1" square mild steel and painted in a black hammer finish gloss.  
 Stalls can be purchased as complete starter kits (steelwork, counter, cover and clips) or as steelwork only.  
 We can manufacture stalls to your specification, please call with your requirements.

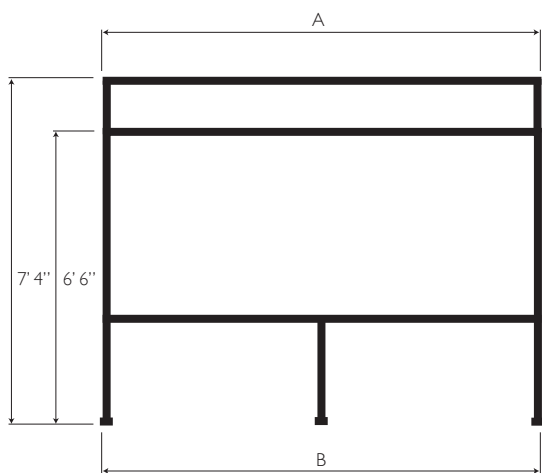

front view

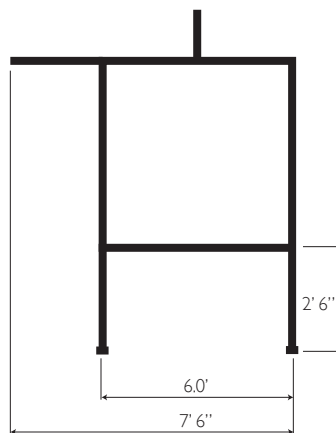

side view

	A	B
6' x 6'	6' 0.5"	6'
8' x 6'	8' 0.5"	8'
10' x 6'	10' 0.5"	10'

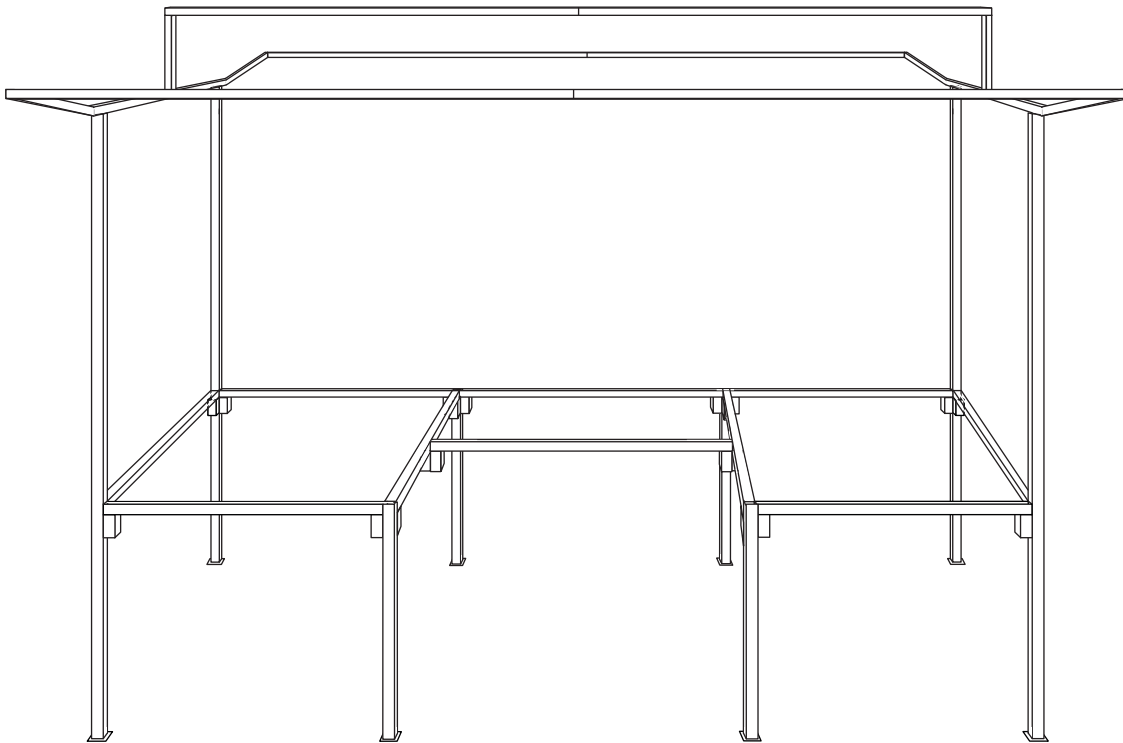
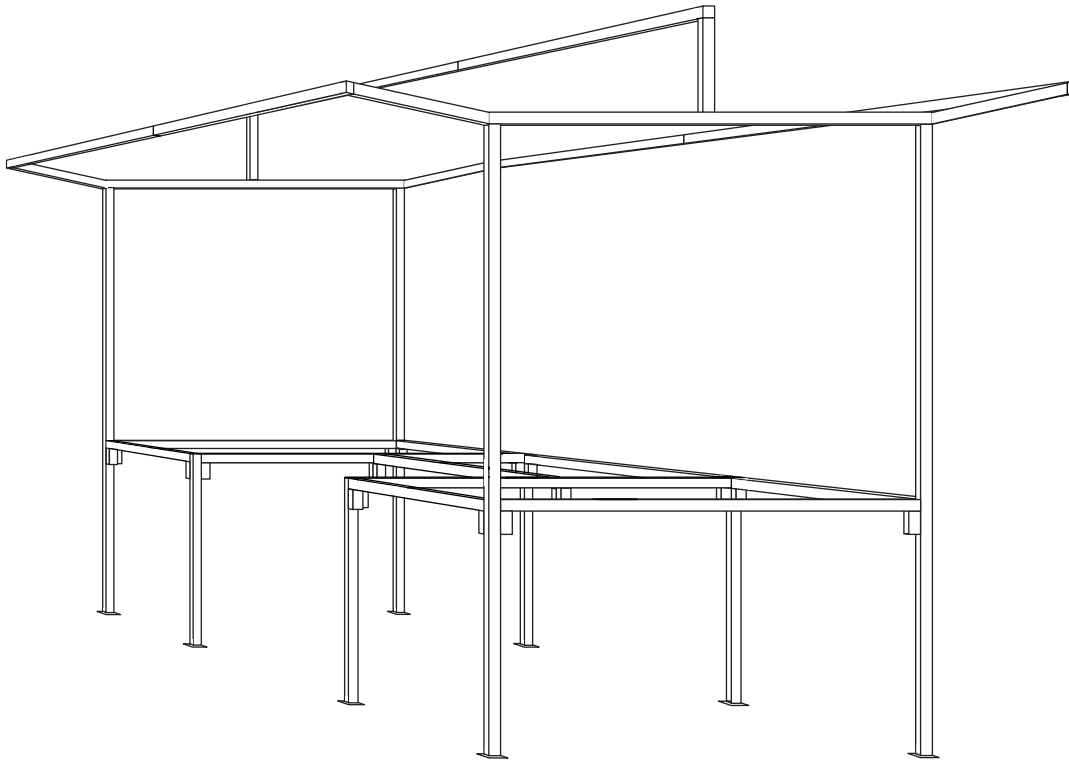

further details overleaf

# DEMONSTRATOR STALLS

8' x 4' and 10' x 4'

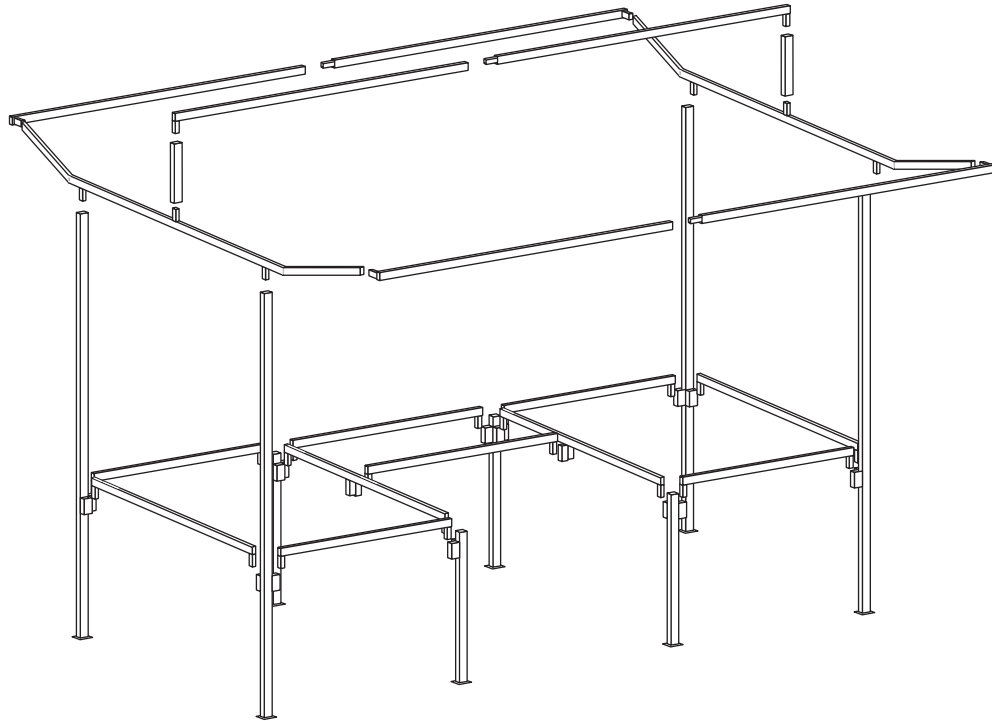

## SPECIFICATIONS

	# OF PARTS	WEIGHT STEEL ONLY / STARTER KIT	COVERS TO SUIT	COUNTERS TO SUIT	MAX. LENGTH
8' x 4'	28	51kg / 61kg	12' x 18' (to cover top and back)	3 off 4' x 2' boards	7.0' (may be reduced)
10' x 4'	28	56kg / 70kg	12' x 18' (to cover top and back)	1 off 4' x 2' board 2 off 3' x 4' boards	7.0' (may be reduced)

All stalls are manufactured using 1" x 1" square mild steel and painted in a black hammer finish gloss. Stalls can be purchased as complete starter kits (steelwork, counter, cover and clips) or as steelwork only. We can manufacture stalls to your specification, please call with your requirements.

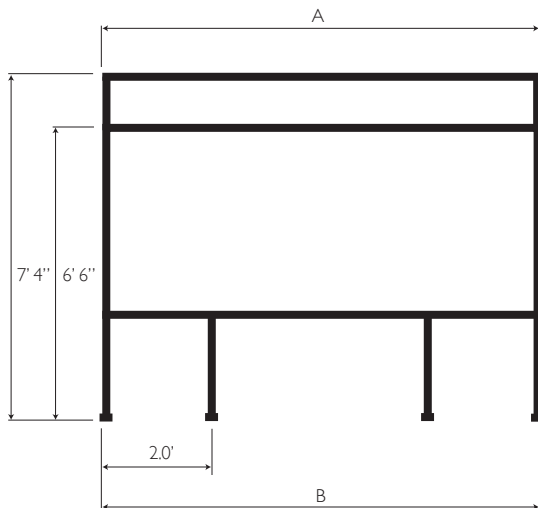

front view

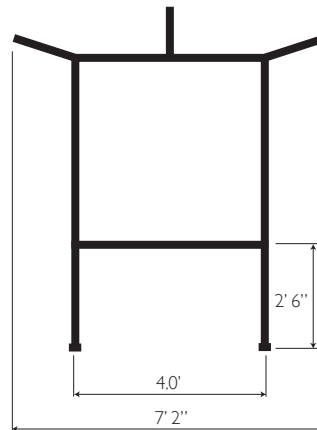

side view

	A	B
8' x 4'	8' 0.5"	8'
10' x 4'	10' 0.5"	10'

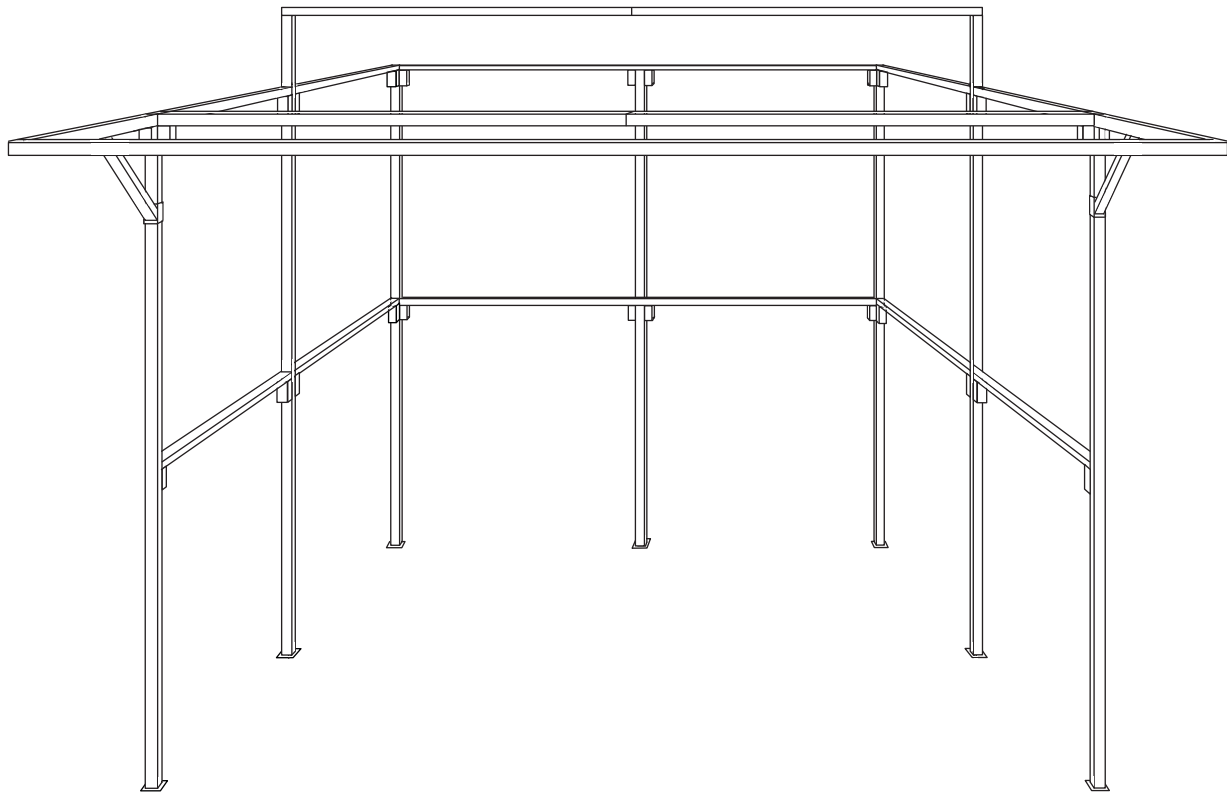
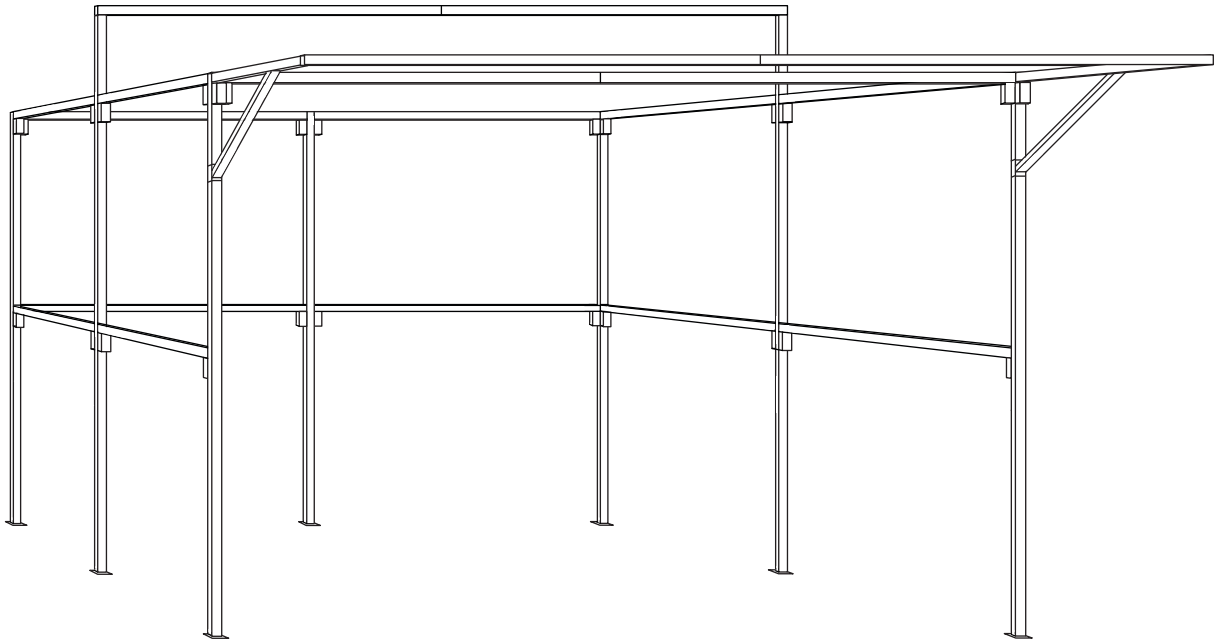

further details overleaf

# FASHION STALLS

10' x 10', 12' x 10', 12' x 12', 14' x 10', 14' x 12' and 14' x 14'

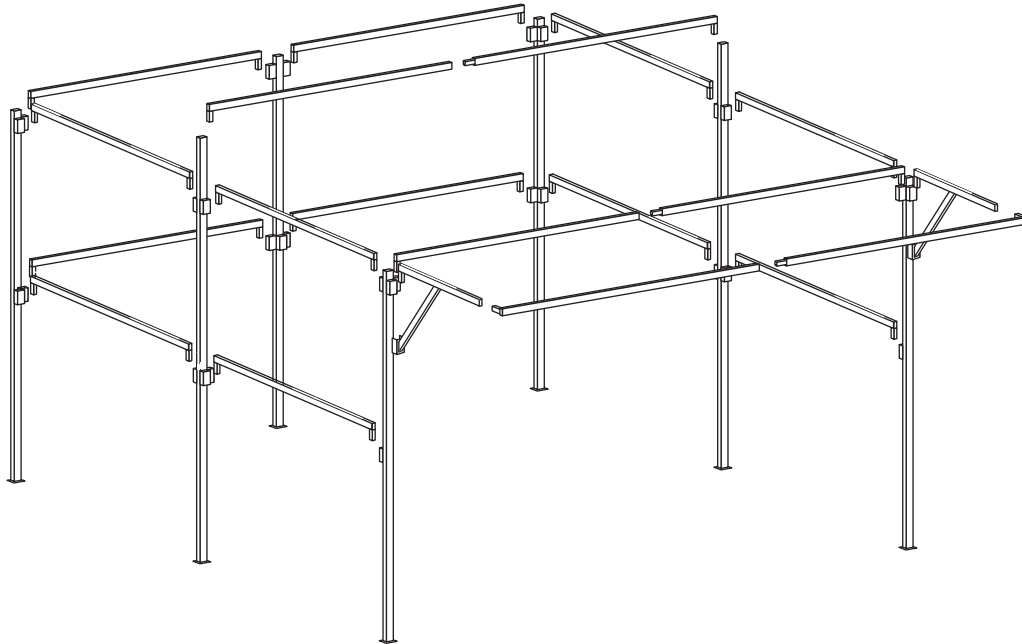

## SPECIFICATIONS

	# OF PARTS	WEIGHT STEEL ONLY / STARTER KIT	COVERS TO SUIT	MAX. LENGTH
10' x 10'	27	73kg / 78kg	1 off 12' x 18' (to cover top and back) 2 off 12' x 9' (to cover sides)	7.0'
12' x 10'	27	79kg / 84kg	1 off 20' x 15' (to cover top and back) 2 off 12' x 9' (to cover sides)	7.0'
12' x 12'	27	83kg / 88kg	1 off 23' x 18' (to cover top and back) 1 off 20' x 15' cut in half (to cover sides)	7.0'
14' x 10'	27	83kg / 88kg	1 off 20' x 15' (to cover top and back) 2 off 12' x 9' (to cover sides)	7' 4.25"
14' x 12'	27	88kg / 93kg	1 off 23' x 18' (to cover top and back) 1 off 20' x 15' cut in half (to cover sides)	7' 4.25"
14' x 14'	27	92kg / 97kg	1 off 23' x 18' (to cover top and back) 1 off 20' x 15' cut in half (to cover sides)	7' 4.25"

All stalls are manufactured using 1" x 1" square mild steel and painted in a black hammer finish gloss.  
Stalls can be purchased as complete starter kits (steelwork, covers and clips) or as steelwork only.  
We can manufacture stalls to your specification, please call with your requirements.

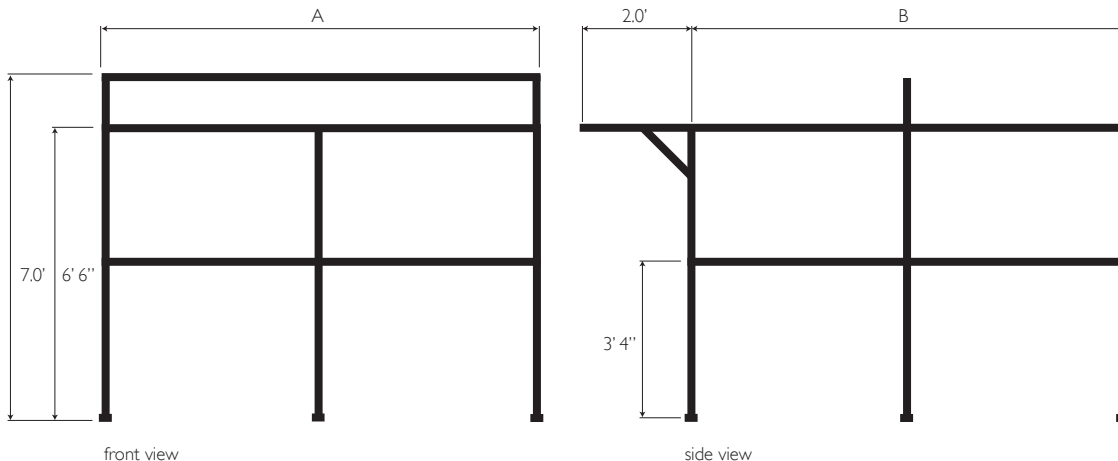

	A	B
10' x 10'	10'	10'
12' x 10'	12'	10'
12' x 12'	12'	12'
14' x 10'	14'	10'
14' x 12'	14'	12'
14' x 14'	14'	14'

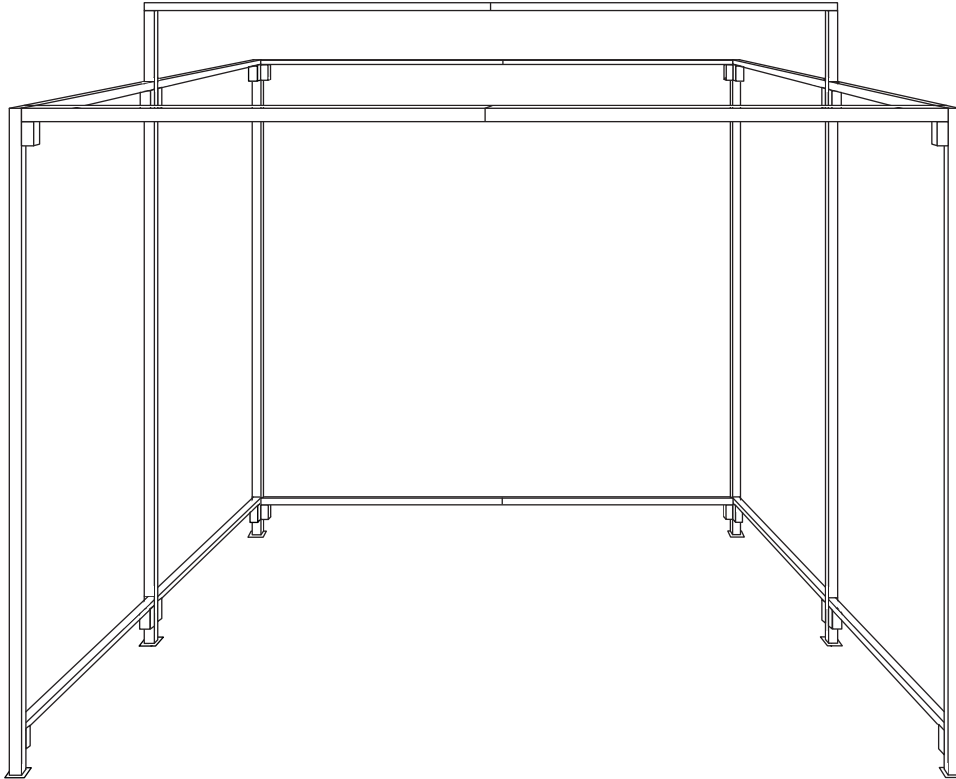
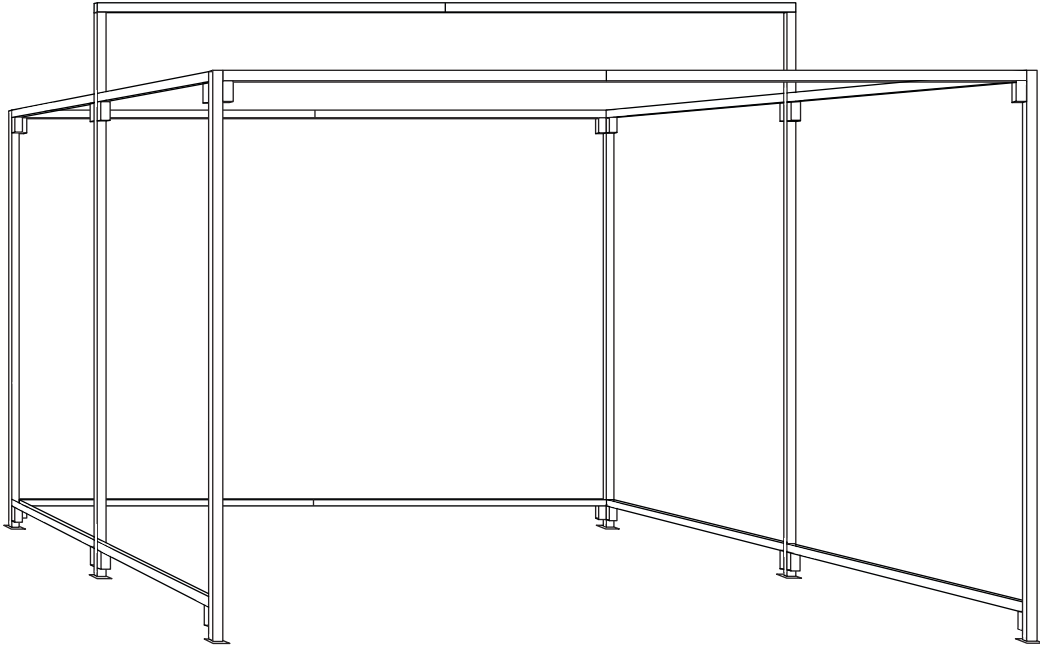

further details overleaf

# GENERAL PURPOSE WALK-IN STALLS

8' x 8', 10' x 10', 12' x 10', 12' x 12', 14' x 12' and 14' x 14'

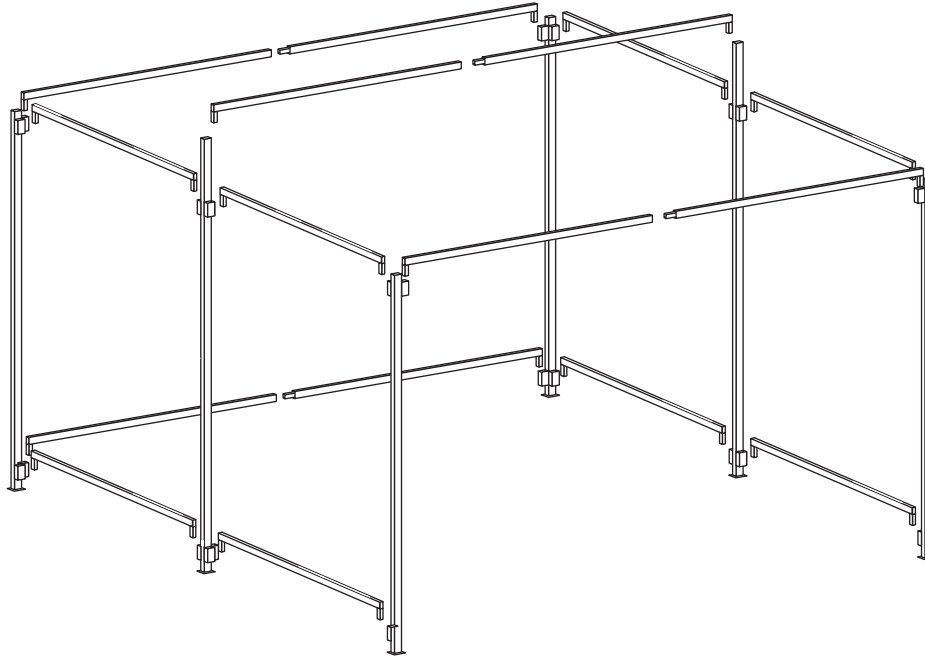

## SPECIFICATIONS

	# OF PARTS	WEIGHT STEEL ONLY / STARTER KIT	COVERS TO SUIT	MAX. LENGTH
8' x 8'	22	52kg / 57kg	1 off 12' x 18' (to cover top and back) 2 off 12' x 9' (to cover sides)	7.0'
10' x 10'	22	60kg / 65kg	1 off 12' x 18' (to cover top and back) 2 off 12' x 9' (to cover sides)	7.0'
12' x 10'	22	64kg / 69kg	1 off 20' x 15' (to cover top and back) 2 off 12' x 9' (to cover sides)	7.0'
12' x 12'	22	68kg / 73kg	1 off 20' x 15' (to cover top and back) 1 off 20' x 15' cut in half (to cover sides)	7.0'
14' x 12'	22	72kg / 77kg	1 off 23' x 18' (to cover top and back) 1 off 20' x 15' cut in half (to cover sides)	7' 4.25"
14' x 14'	22	76kg / 81kg	1 off 23' x 18' (to cover top and back) 1 off 20' x 15' cut in half (to cover sides)	7' 4.25"

All stalls are manufactured using 1" x 1" square mild steel and painted in a black hammer finish gloss.  
Stalls can be purchased as complete starter kits (steelwork, covers and clips) or as steelwork only.  
We can manufacture stalls to your specification, please call with your requirements.

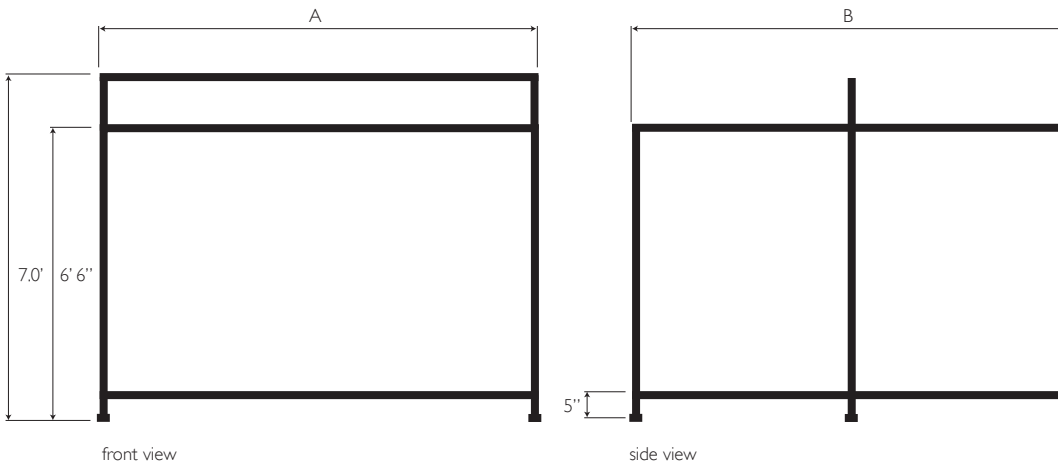

	A	B
8' x 8'	8'	8'
10' x 10'	10'	10'
12' x 10'	12'	10'
14' x 12'	14'	12'
14' x 14'	14'	14'

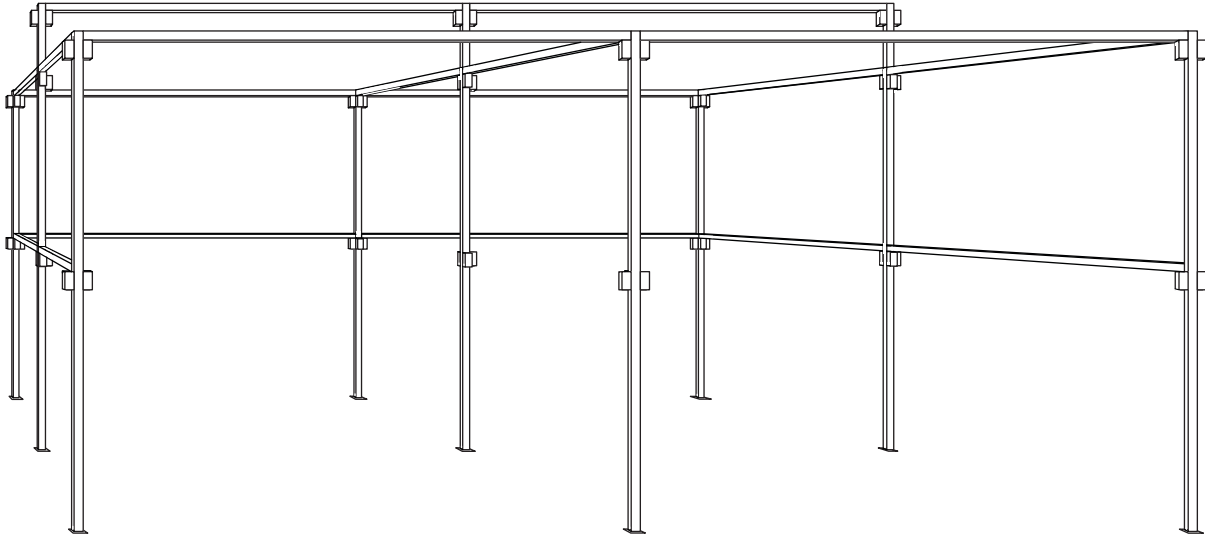

▲ double bay style walk-in

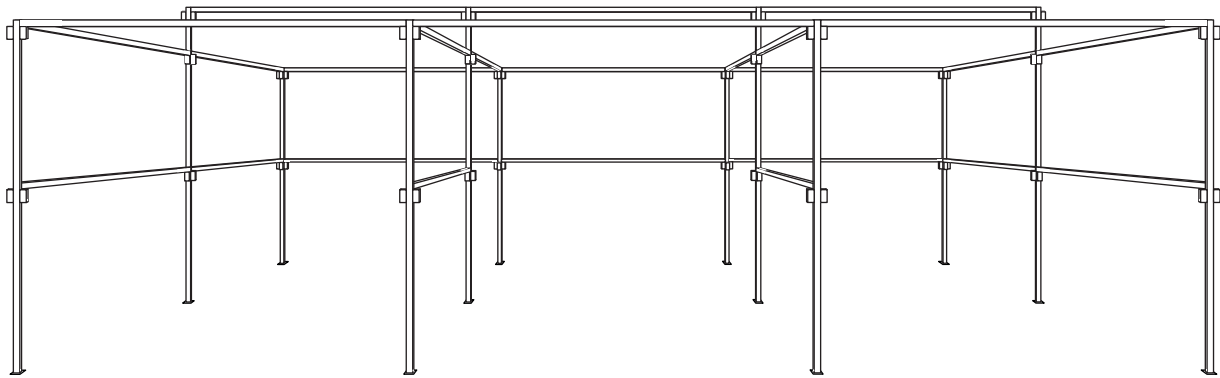

▲ triple bay style walk-in

further details overleaf

# LARGE WALK-IN STALLS

20' x 10', 16' x 16', 24' x 16', 20' x 20', 30' x 20', 32' x 16' and 40' x 20'

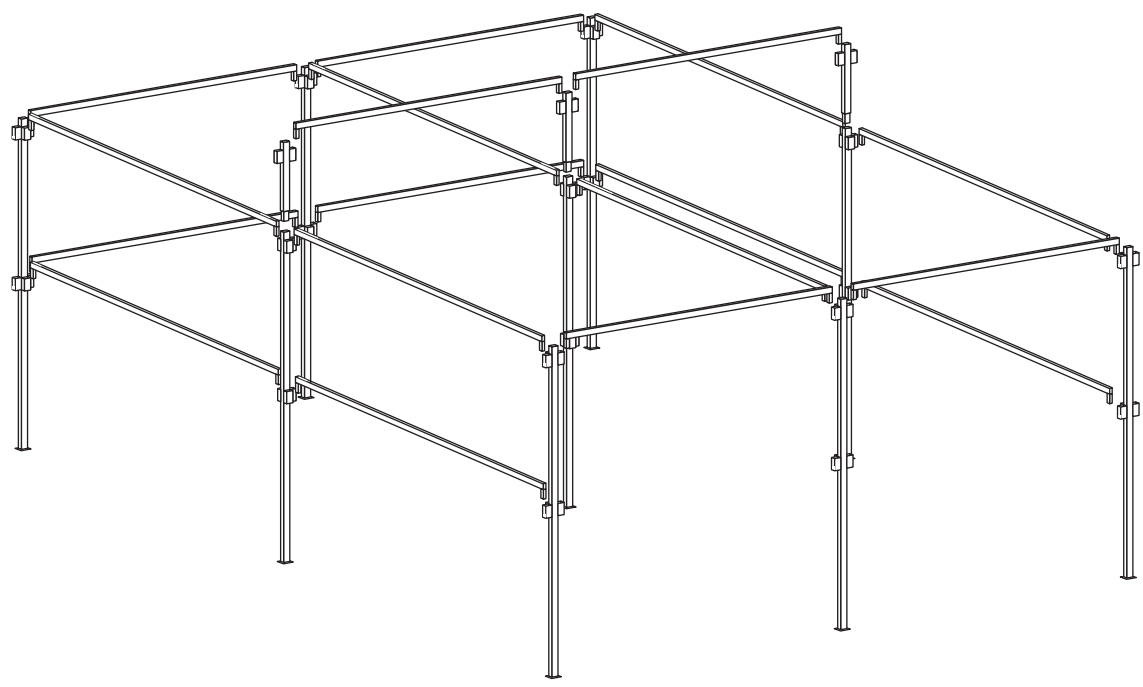

## SPECIFICATIONS

	# OF PARTS	WEIGHT STEEL ONLY / STARTER KIT	COVERS TO SUIT	MAX. LENGTH
20' x 10'	22	80kg / 90kg	1 off 23' x 18' (to cover top and back) 2 off 12' x 9' (to cover sides)	10'
16' x 16'	30	104kg / 109kg	1 off 23' x 18' (to cover top and back) 1 off 20' x 15' cut in half (to cover sides)	8.0'
20' x 20'	30	121kg / 126kg	1 off 29' x 23' (to cover top and back) 1 off 23' x 18' cut in half (to cover sides)	10'
24' x 16'	40	138kg / 146kg	1 off 29' x 23' (to cover top and back) 1 off 20' x 15' cut in half (to cover sides)	8.0'
30' x 20'	40	162kg / 177kg	1 off 35' x 23' (to cover top) 1 off 29' x 23' cut in thirds (to cover sides and back)	10'
32' x 16'	50	173kg / 183kg	1 off 35' x 25' (to cover top) 1 off 29' x 23' cut in thirds (to cover sides and back)	8.0'
40' x 20'	50	203kg / 228kg	1 off 45' x 29' (to cover top and back) 1 off 23' x 18' cut in half (to cover sides)	10'

All stalls are manufactured using 1" x 1" square mild steel and painted in a black hammer finish gloss.  
Stalls can be purchased as complete starter kits (steelwork, covers and clips) or as steelwork only.  
We can manufacture stalls to your specification, please call with your requirements.

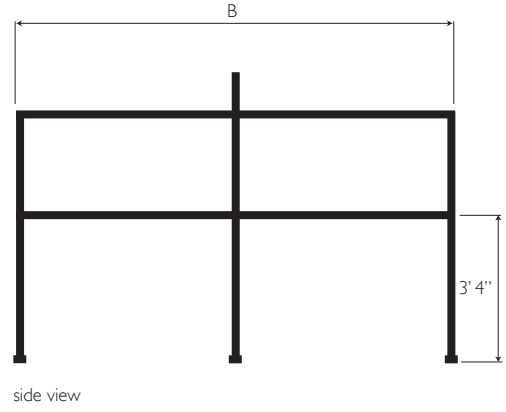
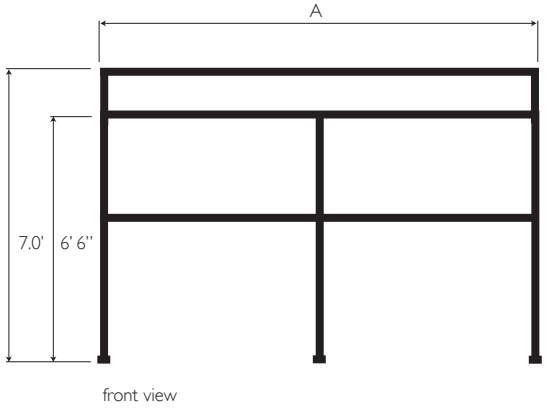

	A	B
20' x 10'	20'	10'
16' x 16'	16'	16'
20' x 20'	20'	20'
24' x 16'	24'	16'
30' x 20'	30'	20'
32' x 16'	32'	16'
40' x 20'	40'	20'

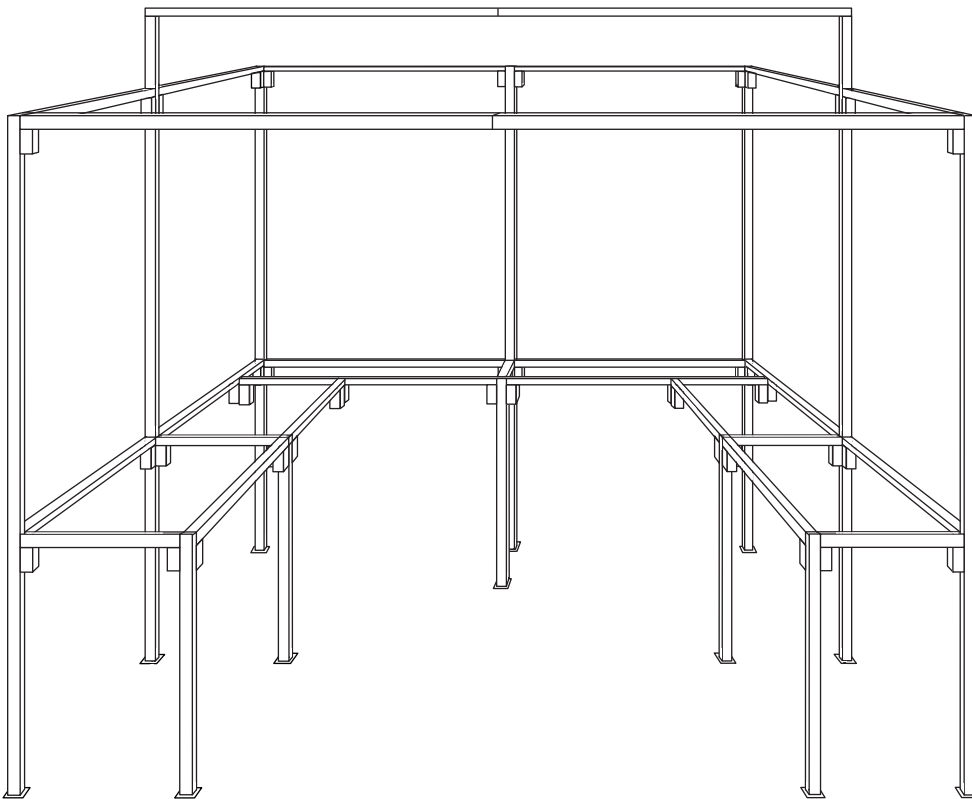
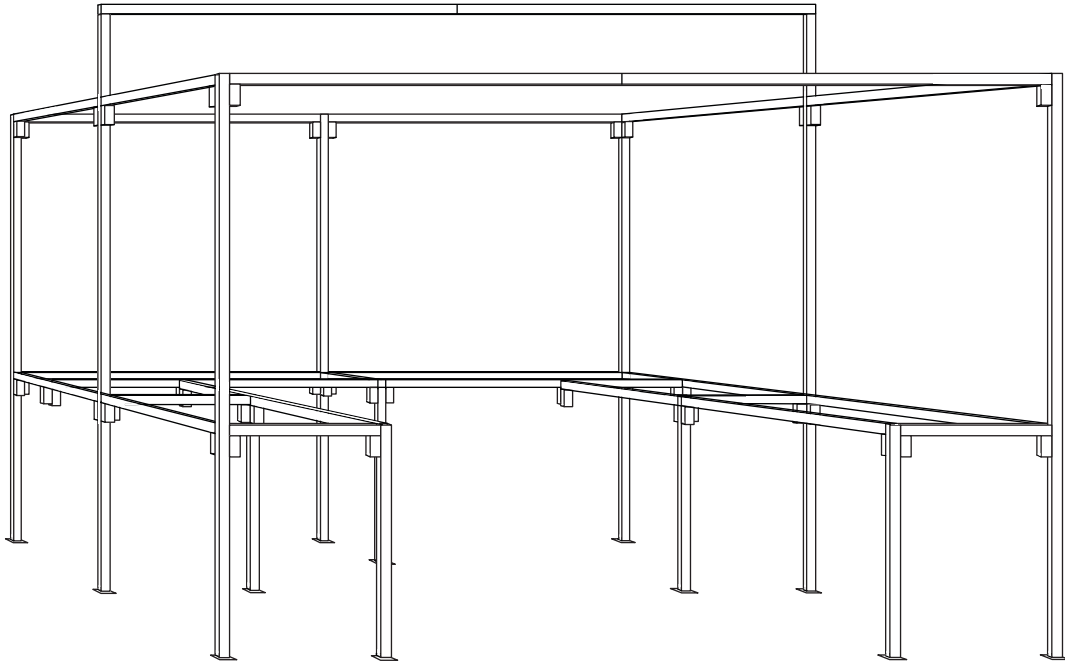

further details overleaf

# WALK-IN STALLS WITH COUNTERS

10' x 10', 12' x 10', 12' x 12', 14' x 12' and 14' x 14'

**GAVIN KENNING**  
engineering

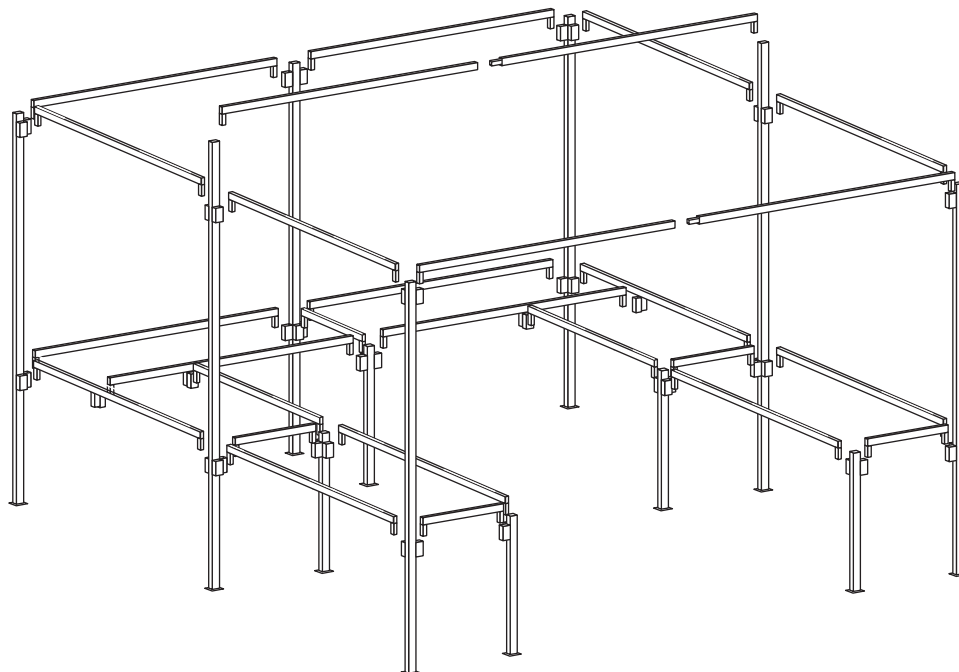

## SPECIFICATIONS

	# OF PARTS	WEIGHT STEEL ONLY / STARTER KIT	COVERS TO SUIT	COUNTERS TO SUIT	MAX. LENGTH
10' x 10'	37	90kg / 112kg	1 off 12' x 18' (to cover top and back) 2 off 12' x 9' (to cover sides)	6 off 4' x 2' 1 off 2' x 2'	7.0'
12' x 10'	37	95kg / 119kg	1 off 20' x 15' (to cover top and back) 2 off 12' x 9' (to cover sides)	7 off 4' x 2'	7.0'
12' x 12'	37	100kg / 130kg	1 off 20' x 15' (to cover top and back) 1 off 20' x 15' cut in half (to cover sides)	8 off 4' x 2'	7.0'
14' x 12'	37	105kg / 134kg	1 off 23' x 18' (to cover top and back) 1 off 20' x 15' cut in half (to cover sides)	8 off 4' x 2' 1 off 2' x 2'	7' 4.25"
14' x 14'	37	111kg / 143kg	1 off 23' x 18' (to cover top and back) 1 off 20' x 15' cut in half (to cover sides)	9 off 4' x 2' 1 off 2' x 2'	7' 4.25"

All stalls are manufactured using 1" x 1" square mild steel and painted in a black hammer finish gloss. Stalls can be purchased as complete starter kits (steelwork, counters, covers and clips) or as steelwork only. We can manufacture stalls to your specification, please call with your requirements.

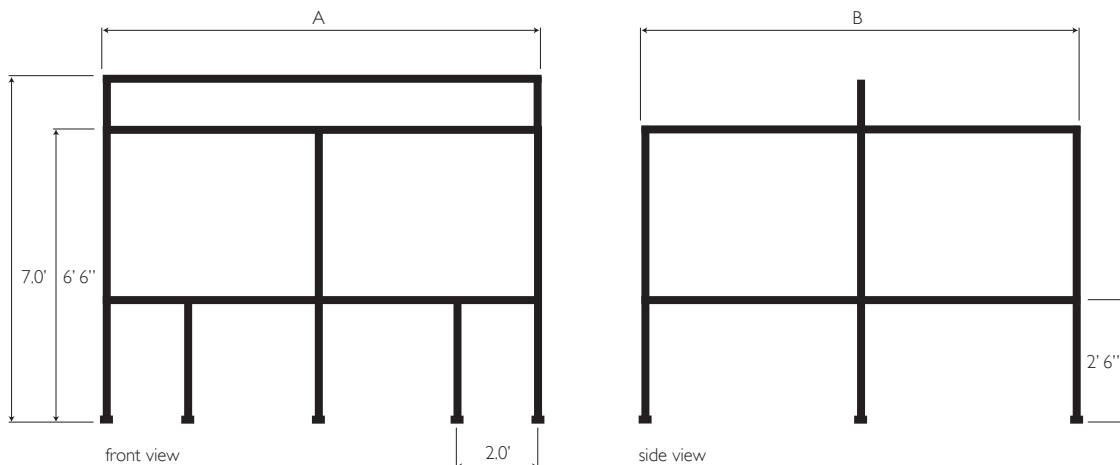

	A	B
10' x 10'	10'	10'
12' x 10'	12'	10'
12' x 12'	12'	12'
14' x 12'	14'	12'
14' x 14'	14'	14'

p. 24 Call today on 01773 607505 or visit us online at [www.market-stalls.co.uk](http://www.market-stalls.co.uk)

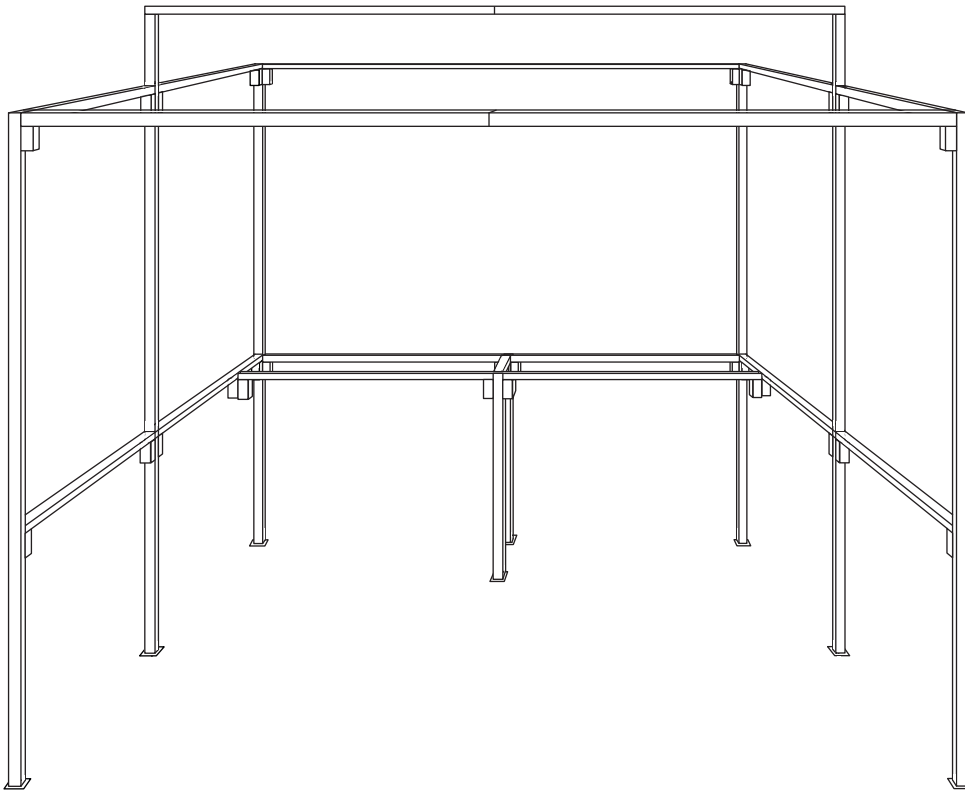
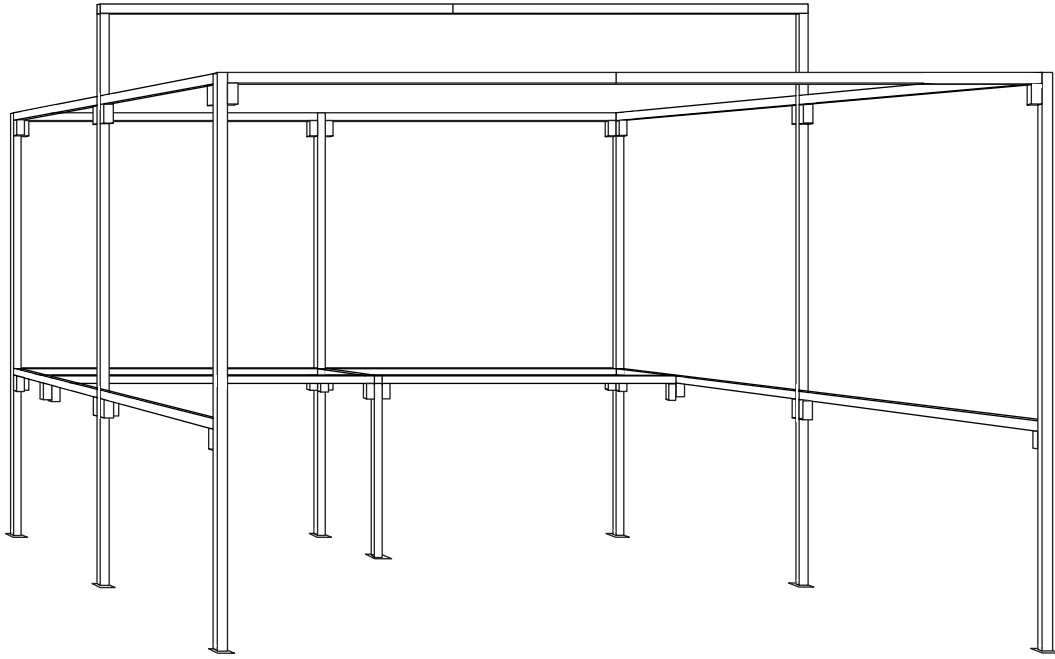

further details overleaf

# WALK-IN STALLS WITH REAR COUNTERS

8' x 8', 10' x 10', 12' x 10', 12' x 12', 14' x 12' and 14' x 14'

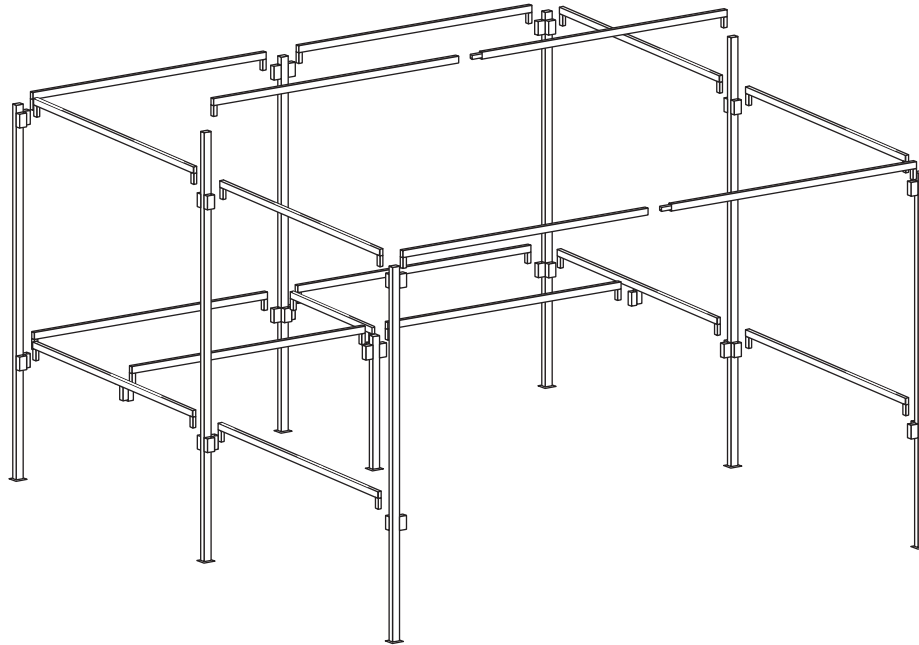

## SPECIFICATIONS

	# OF PARTS	WEIGHT STEEL ONLY / STARTER KIT	COVERS TO SUIT	COUNTERS TO SUIT	MAX. LENGTH
8' x 8'	27	62kg / 69kg	1 off 12' x 18' (to cover top and back) 2 off 12' x 9' (to cover sides)	2 off 4' x 2'	7.0'
10' x 10'	27	70kg / 78kg	1 off 12' x 18' (to cover top and back) 2 off 12' x 9' (to cover sides)	2 off 4' x 2' 1 off 2' x 2'	7.0'
12' x 10'	27	76kg / 86kg	1 off 20' x 15' (to cover top and back) 2 off 12' x 9' (to cover sides)	3 off 4' x 2'	7.0'
12' x 12'	27	80kg / 90kg	1 off 20' x 15' (to cover top and back) 1 off 20' x 15' cut in half (to cover sides)	3 off 4' x 2'	7.0'
14' x 12'	27	85kg / 97kg	1 off 23' x 18' (to cover top and back) 1 off 20' x 15' cut in half (to cover sides)	3 off 4' x 2' 1 off 2' x 2'	7' 4.25"
14' x 14'	27	89kg / 101kg	1 off 23' x 18' (to cover top and back) 1 off 20' x 15' cut in half (to cover sides)	3 off 4' x 2' 1 off 2' x 2'	7' 4.25"

All stalls are manufactured using 1" x 1" square mild steel and painted in a black hammer finish gloss.  
Stalls can be purchased as complete starter kits (steelwork, covers and clips) or as steelwork only.  
We can manufacture stalls to your specification, please call with your requirements.

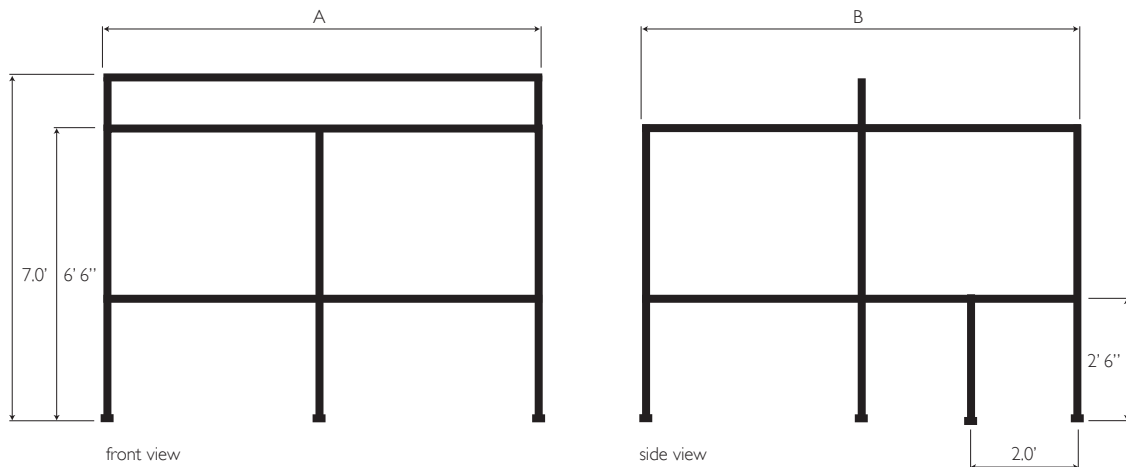

	A	B
8' x 8'	8'	8'
10' x 10'	10'	10'
12' x 10'	12'	10'
12' x 12'	12'	12'
14' x 12'	14'	12'
14' x 14'	14'	14'

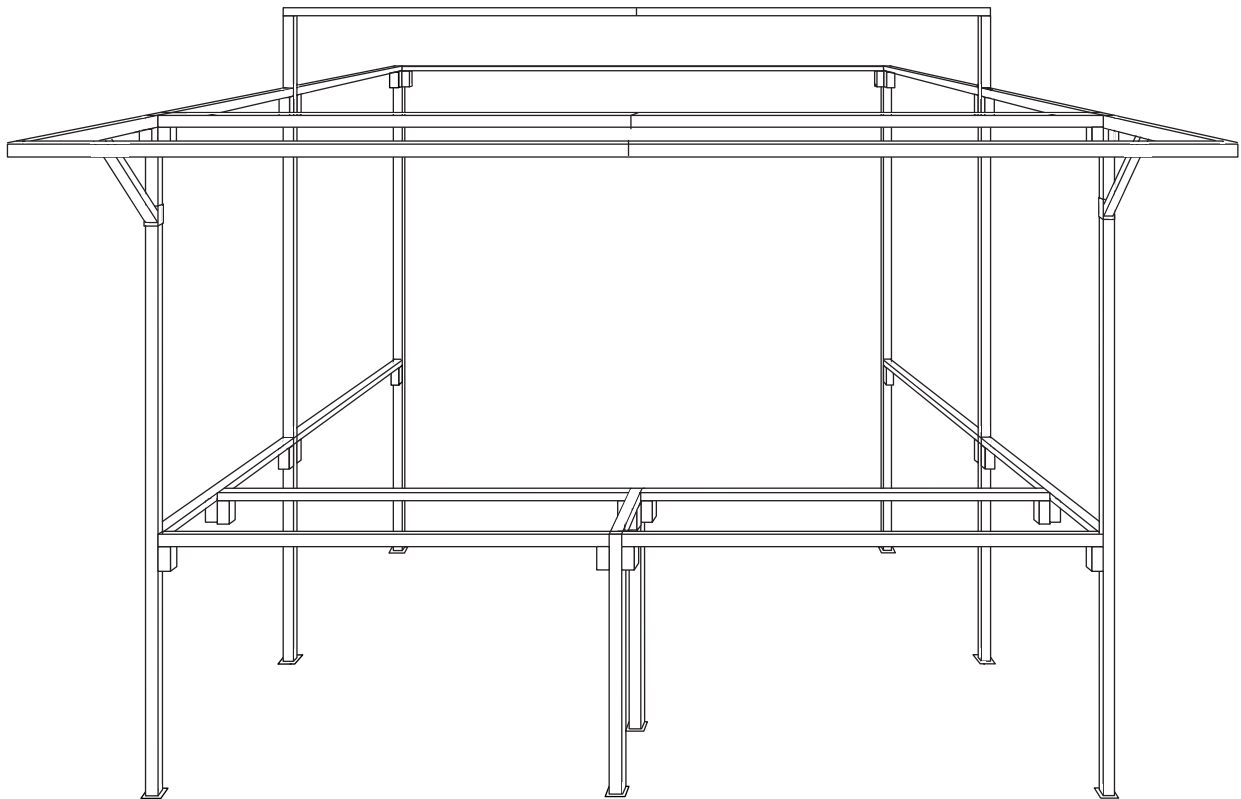
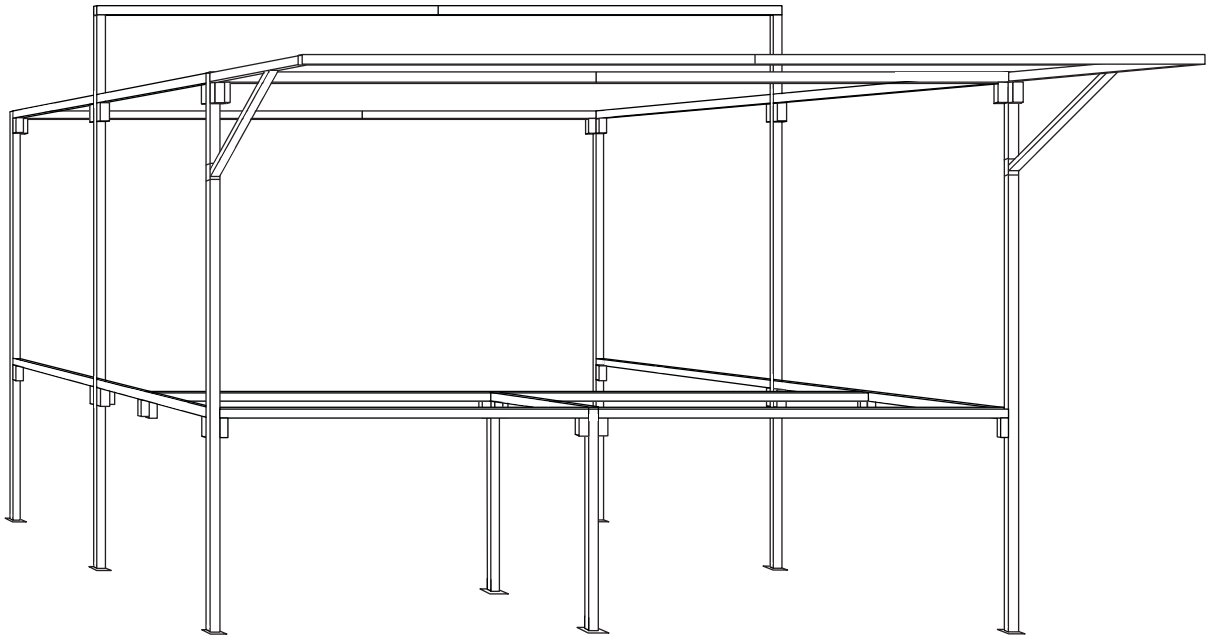

further details overleaf

# WALK-IN STALLS WITH FRONT COUNTERS

8' x 8', 10' x 8', 12' x 8'

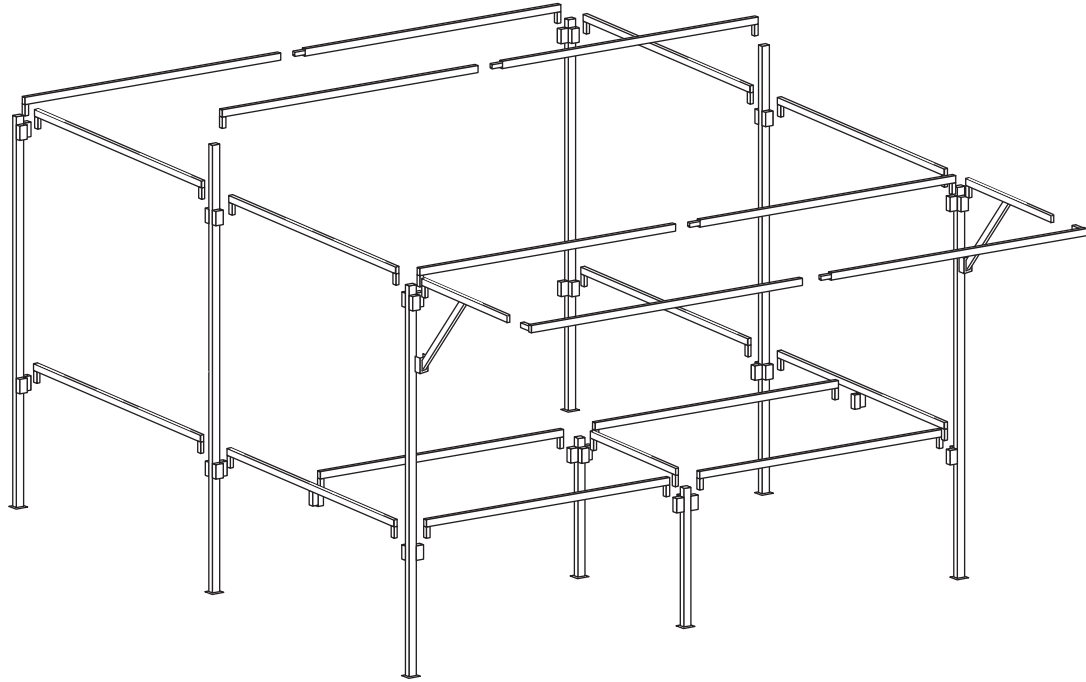

## SPECIFICATIONS

	# OF PARTS	WEIGHT STEEL ONLY / STARTER KIT	COVERS TO SUIT	COUNTERS TO SUIT	MAX. LENGTH
8' x 8'	31	67kg / 74kg	1 off 12' x 18' (to cover top and back) 2 off 12' x 9' (to cover sides)	2 off 4' x 2'	7.0'
10' x 8'	31	74kg / 82kg	1 off 12' x 18' (to cover top and back) 2 off 12' x 9' (to cover sides)	2 off 4' x 2' 1 off 2' x 2'	7.0'
12' x 8'	31	80kg / 90kg	1 off 20' x 15' (to cover top and back) 2 off 12' x 9' (to cover sides)	3 off 4' x 2'	7.0'

All stalls are manufactured using 1" x 1" square mild steel and painted in a black hammer finish gloss.  
Stalls can be purchased as complete starter kits (steelwork, counters, covers and clips) or as steelwork only.  
We can manufacture stalls to your specification, please call with your requirements.

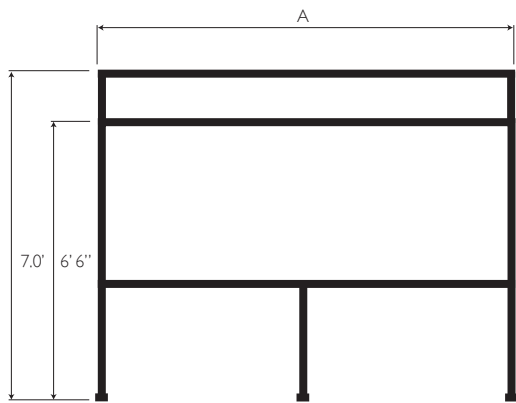

front view

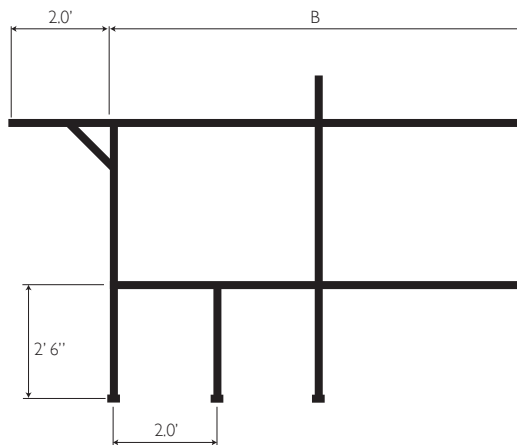

side view

	A	B
8' x 8'	8'	8'
10' x 8'	10'	8'
12' x 8'	12'	8'

**FASHION SOLUTIONS**

Our range of square section dress rails are renowned for their strength and simplicity having no small parts that can be misplaced. All our rails can be taken apart quickly and easily and pack flat for transportation or storage.

Rails may be used in conjunction with conventional clothes hangers as well as our extensive range of hanger brackets that fit directly onto the square section tubing enabling you to create your own professional and individual clothing displays which can be fronted up to the customer for maximum effect.

All our rails can be supplied with wheels (either standard or heavy duty) or simply as flat bottomed rails.

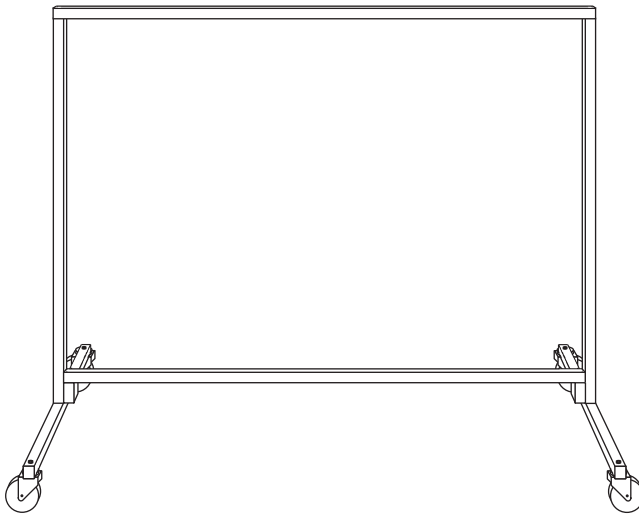

◀ standard dress rail (with wheels)

▶ two tier dress rail (with wheels)

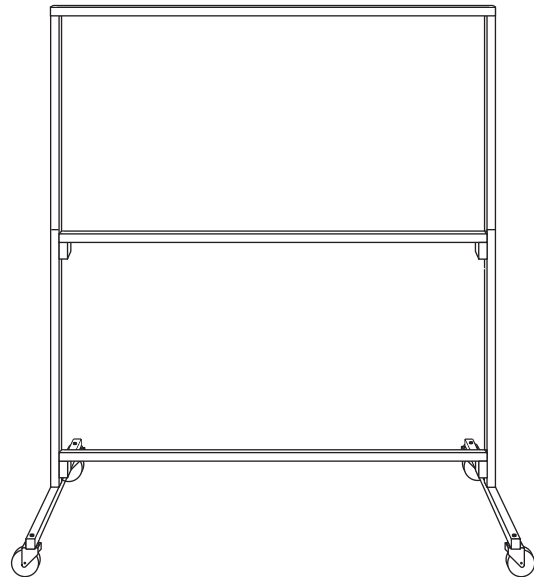

further details overleaf

# DRESS RAILS

various sizes available (see below)

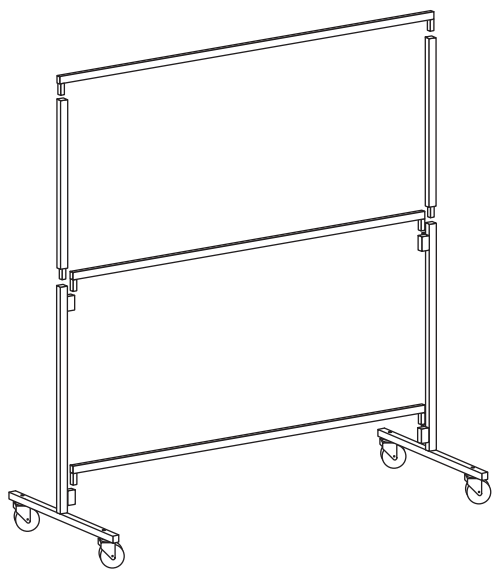
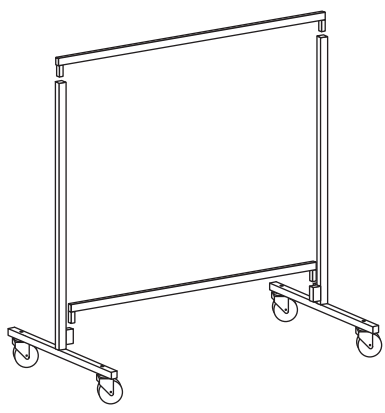

## SPECIFICATIONS

	TYPE OF RAIL	# OF PARTS	WEIGHT WITH WHEELS / FLAT BOTTOMED	MAX. LENGTH
4' x 4'	standard (junior)	4	12kg / 10kg	4'
4' x 5' 3"	standard	4	13kg / 11kg	5' 3"
5' x 5' 3"	standard	4	14kg / 12kg	5' 3"
6' x 5' 3"	standard	4	15kg / 13kg	5' 3"
4' x 6'	two tier	7	18kg / 16kg	6'
5' x 6'	two tier	7	20kg / 18kg	6'
6' x 6'	two tier	7	22kg / 20kg	6'

All dress rails are manufactured using 1" x 1" square mild steel and painted in a black hammer finish gloss.  
 Dress rails can be purchased with wheels (either standard or heavy duty) or as flat bottomed rails only.  
 We can manufacture dress rails to your specification, please call with your requirements.

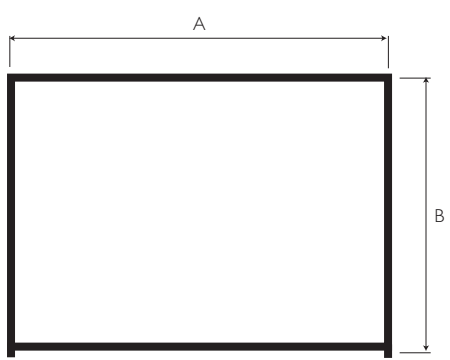

standard dress rail

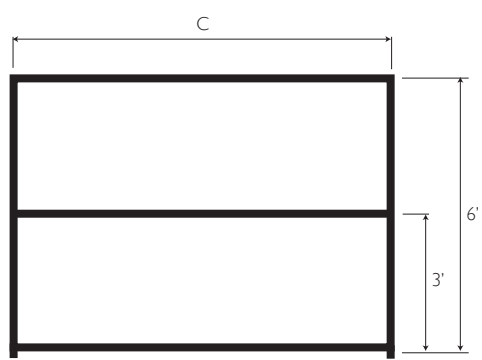

two tier dress rail

Wheels will add approximately 4" to overall height of dress rail

	A	B	C
4' x 4'	4'	4'	-
4' x 5' 3"	4'	5' 3"	-
5' x 5' 3"	5'	5' 3"	-
6' x 5' 3"	6'	5' 3"	-
4' x 6'	-	-	4'
5' x 6'	-	-	5'
6' x 6'	-	-	6'

**INCREASE YOUR SELLING SPACE**

Our range of tough, portable tables are invaluable for additional indoor or outdoor selling space and have the great advantage of totally dismantling and packing into a small space for transportation or storage.

Tables are manufactured from the same steel and employ the same construction techniques as those used in making our renown market stalls.

We can supply table counters which are made from 9mm plywood, see overleaf for details. Alternatively any suitable timber boards may be used.

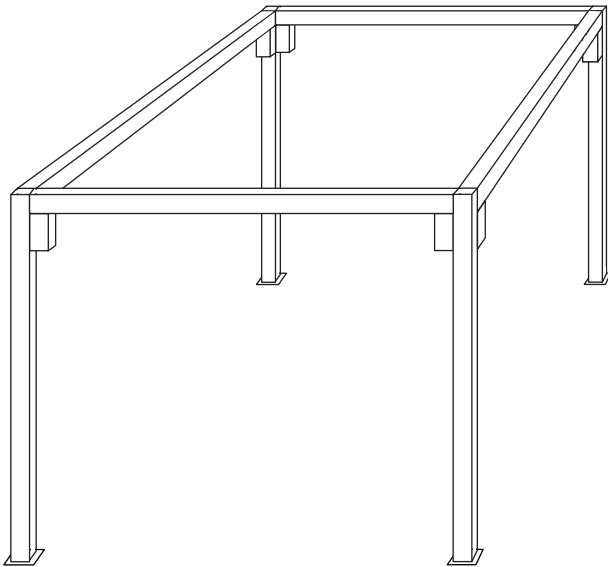

◀ small table (various sizes available)

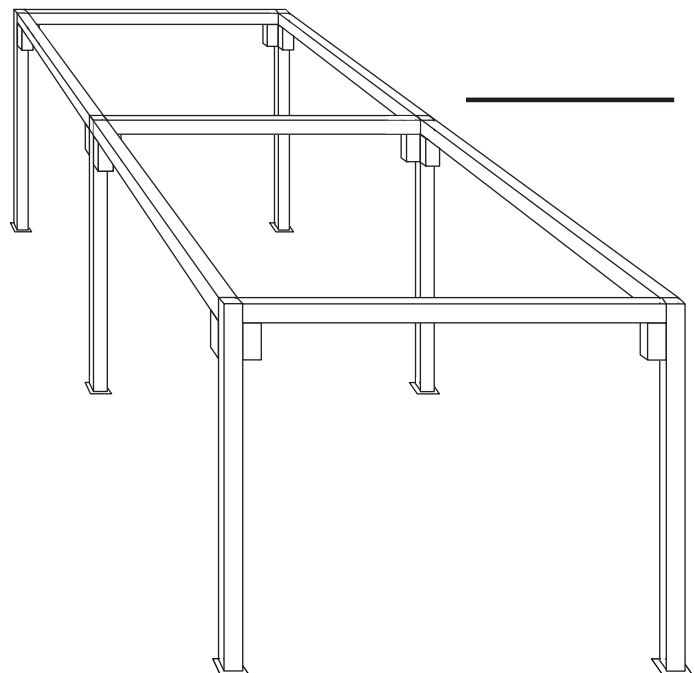

▶ large table (various sizes available)

further details overleaf

# TABLES

various sizes available (see below)

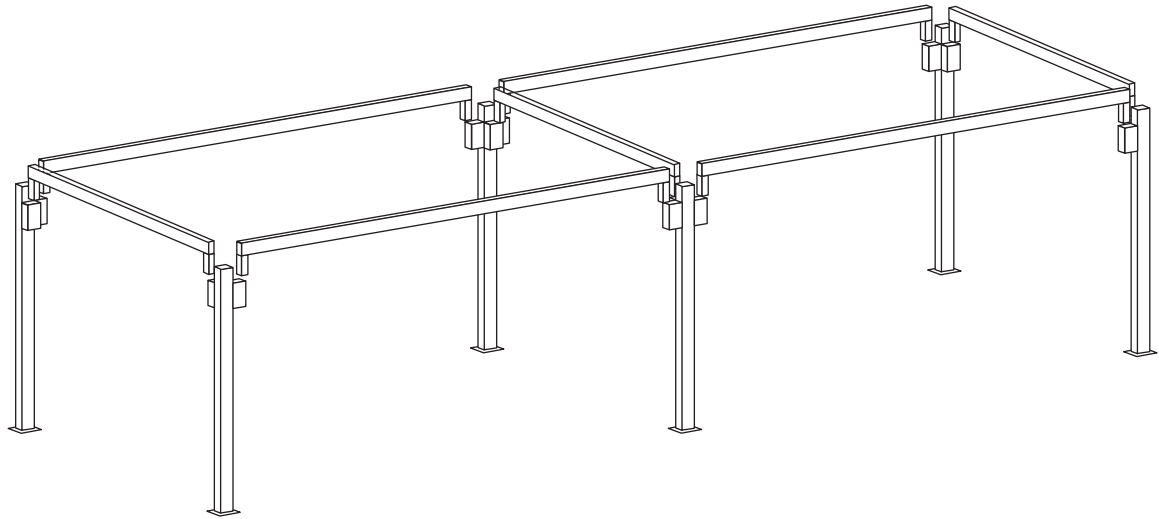

## SPECIFICATIONS

### SMALL TABLES

	# OF PARTS	WEIGHT STEEL ONLY / STEEL + COUNTER	COUNTERS TO SUIT	MAX. LENGTH
2' x 4'	8	11kg / 14.5kg	1 off 4' x 2' board	3' 10"
3' x 4'	8	14kg / 19kg	2 off 3' x 2' boards	3' 10"
4' x 4'	9*	15kg / 22kg	2 off 4' x 2' boards	3' 10"
2' x 5'	8	12kg / 17kg	1 off 5' x 2' board	4' 10"
3' x 5'	8	15.5kg / 22kg	2 off 3' x 2' 6" boards	4' 10"
4' x 5'	9*	16.5kg / 21kg	2 off 2' x 2' 6" boards	4' 10"
2' x 6'	8	13kg / 18kg	2 off 2' x 3' boards	5' 10"
3' x 6'	8	17kg / 25kg	2 off 3' x 3' boards	5' 10"
4' x 6'	9*	18kg / 28kg	3 off 2' x 4' boards	5' 10"

### LARGE TABLES

	# OF PARTS	WEIGHT STEEL ONLY / STEEL + COUNTER	COUNTERS TO SUIT	MAX. LENGTH
2' x 8'	13	18.5kg / 25kg	2 off 4' x 2' boards	3' 10"
3' x 8'	13	24kg / 35kg	4 off 3' x 2' boards	3' 10"
4' x 8'	15*	25.5kg / 39kg	4 off 4' x 2' boards	3' 10"
2' x 10'	13	20.5kg / 28kg	2 off 5' x 2' boards	4' 10"
3' x 10'	13	27kg / 41kg	5 off 3' x 2' boards	4' 10"
4' x 10'	15*	28.5kg / 45kg	5 off 4' x 2' boards	4' 10"
2' x 12'	13	22.5kg / 32.5kg	3 off 4' x 2' boards	5' 10"
3' x 12'	13	30kg / 46kg	6 off 3' x 2' boards	5' 10"
4' x 12'	15*	31.5kg / 51.5kg	6 off 4' x 2' boards	5' 10"
2' x 14'	13	24.5kg / 35.5kg	2 off 5' x 2' boards 1 off 4' x 2' board	6' 10"
3' x 14'	13	33kg / 53kg	7 off 3' x 2' boards	6' 10"
4' x 14'	15*	34.5kg / 58kg	7 off 4' x 2' boards	6' 10"

\* additional counter support(s) supplied

All tables are manufactured using 1" x 1" square mild steel and painted in a black hammer finish gloss. Tables can be purchased with wooden counters or as steelwork only. We can manufacture tables to your specification, please call with your requirements.

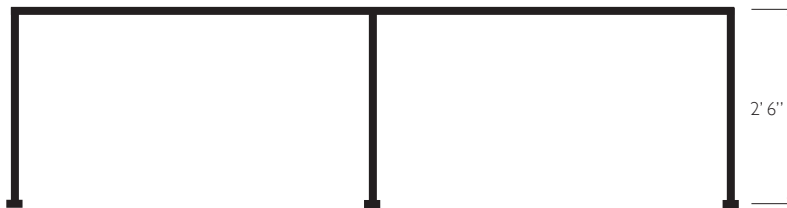

291207

**COMPLIMENT YOUR PRODUCTS WITH OUT STEP DISPLAY STANDS**

Our step displays will help to compliment your products bringing items closer to the customer's eye level and enabling more products to be effectively displayed in the same space.

Step displays are a simple, flexible and very rugged solution, manufactured from the same steel and employing the same construction techniques as those used in making our renown market stalls.

The displays are designed to be flat packed and easily transportable by simply detaching the back leg from the step. They are a stand-alone fabrication that could be used on any market stall, table or flat surface. By spacing the supports further apart the display lengths can be varied providing greater flexibility. Any suitable board can be used to form the steps, this is then usually covered with a cloth or grass matt to form a backdrop for your products.

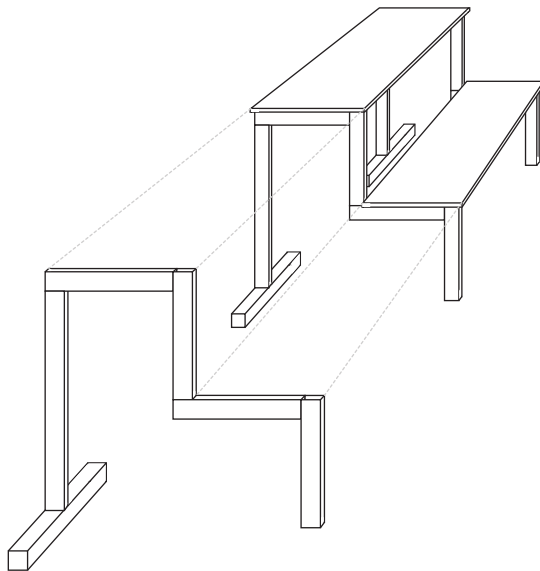
**◀ 9" x 9" 2 step display****TYPICAL USES**

To display shoes, household items, electrical equipment, books or any medium sized items

**▶ 6" x 6" 3 step display****TYPICAL USES**

To display watches, perfumes, fashion jewellery, hair accessories, ornaments or mobile phones and their accessories

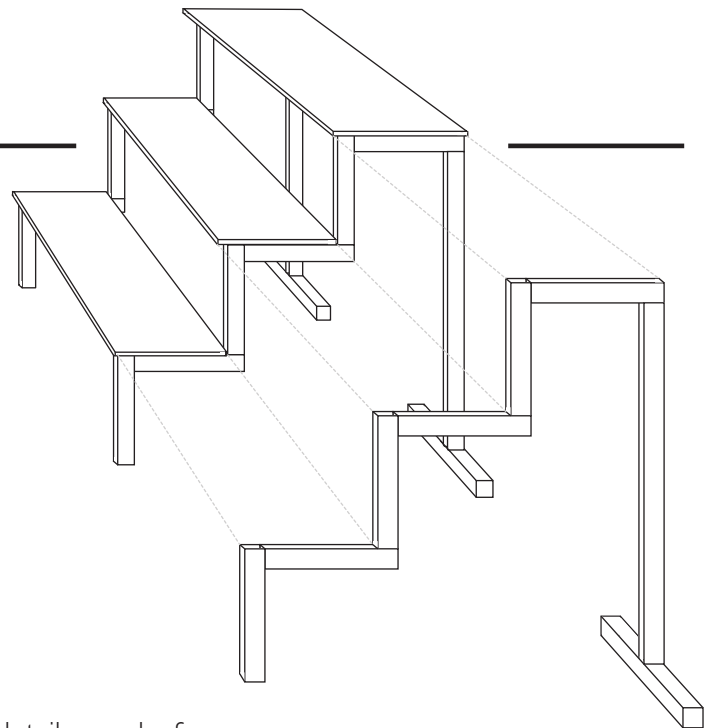

further details overleaf

# STEP DISPLAYS

9" x 9" and 6" x 6"

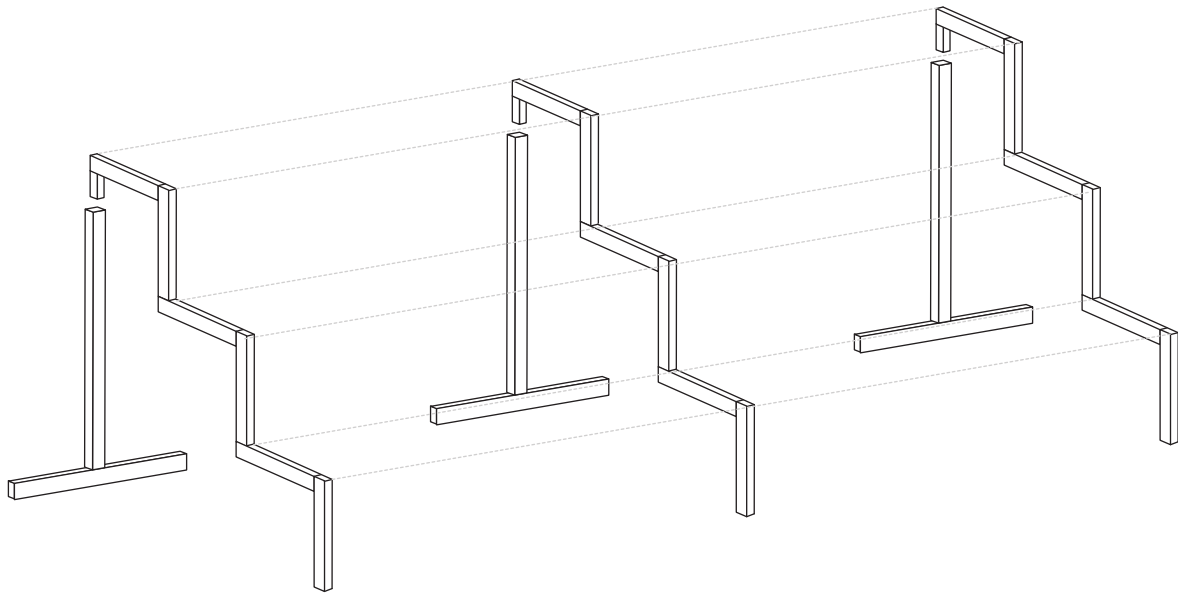

## SPECIFICATIONS

	# OF PARTS	WEIGHT STEEL ONLY / STEEL + COUNTER	COUNTERS TO SUIT	TYPICAL LENGTH
<b>9" x 9"</b> (2 step)	6 (3 steps, 3 legs)	15kg / 33kg	4 off 9" x 4' boards	8' (variable)
<b>6" x 6"</b> (3 step)	6 (3 steps, 3 legs)	15kg / 33kg	6 off 6" x 4' boards	8' (variable)

All step displays are manufactured using 1" x 1" square mild steel and painted in a black hammer finish gloss.  
 Step displays can be purchased with wooden counters/steps or as steelwork only.  
 We can manufacture step displays to your specification, please call with your requirements.

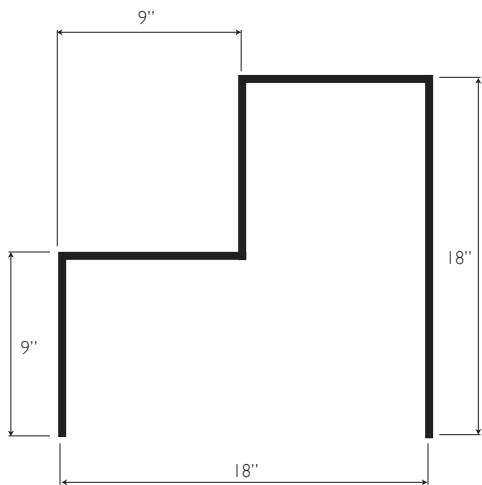

9" x 9" 2 step display

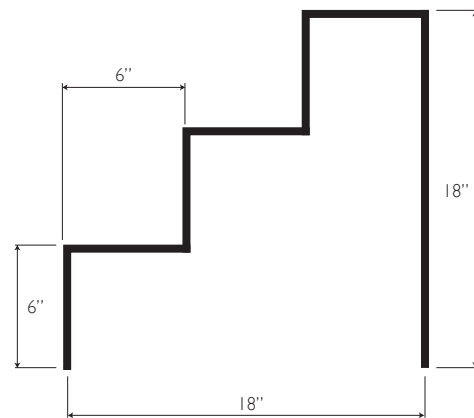

6" x 6" 3 step display

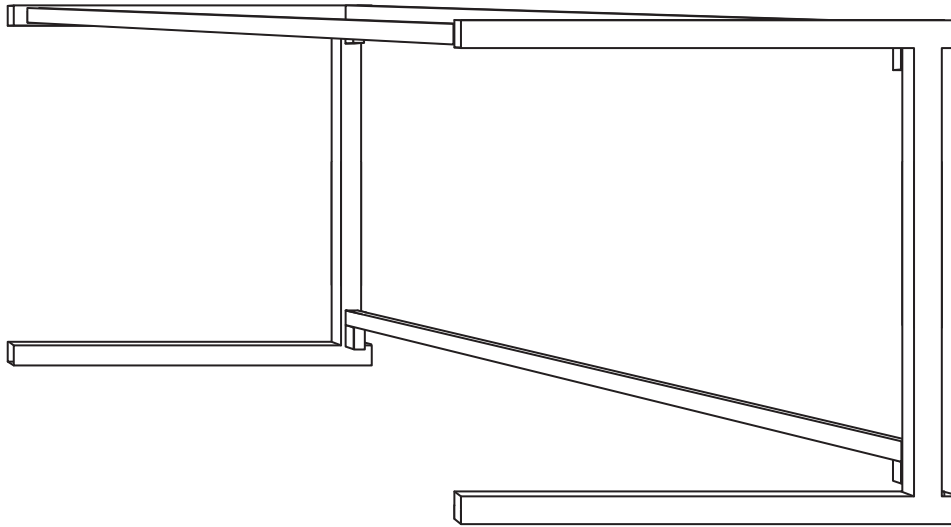

▲ single tier sofa display stand

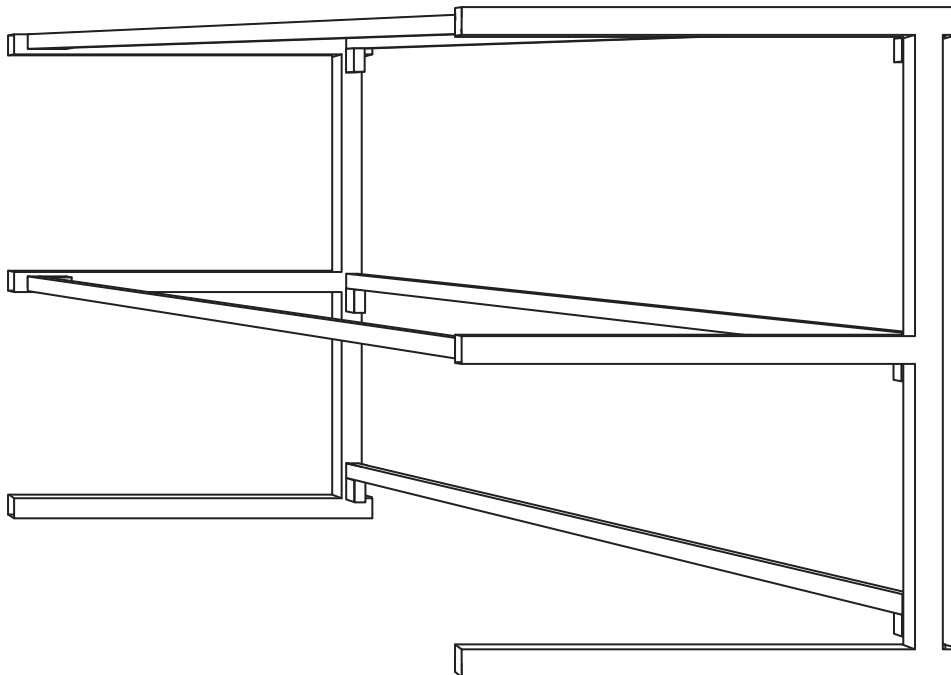

▲ double tier sofa display stand

further details overleaf

# SOFA DISPLAY STANDS

Single and Double Tier

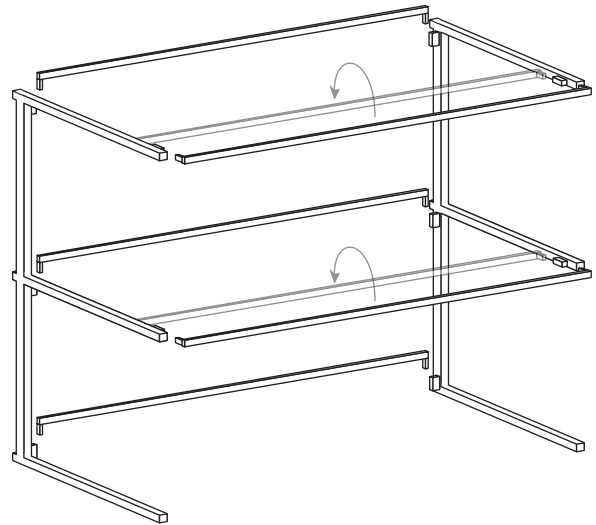
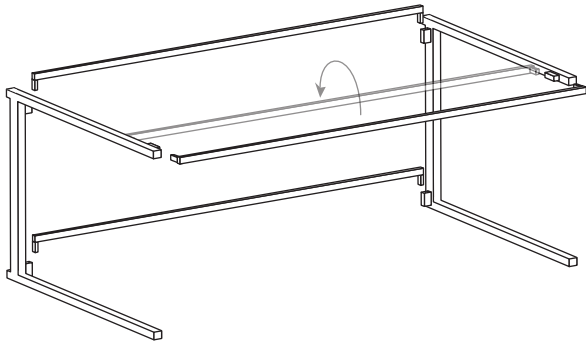

## SPECIFICATIONS

	# OF PARTS	WEIGHT	DIMENSIONS (l x d x h)	MAX. LENGTH
<b>Single Tier</b>	6 (3 steps, 3 legs)	12.5kg	4' x 30" x 40"	45.5"
<b>Double Tier</b>	6 (3 steps, 3 legs)	17kg	4' x 30" x 80"	80"

All sofa display stands are manufactured using a combination of 1" x 1" and 1 1/4" x 1 1/4" square mild steel and painted in a black hammer finish gloss. We can manufacture sofa display stands to your specification, please call with your requirements.

Front most upper support bar(s) on both single and double tier sofa display stands can be rotated horizontally to give a depth of 30" or 24" (see diagrams above) which will accommodate most sofas and 3-piece suites

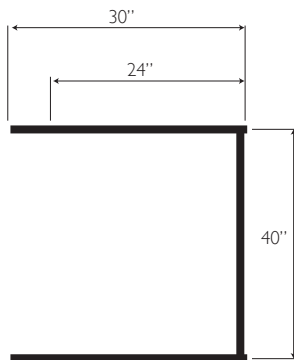

Single tier sofa display stand

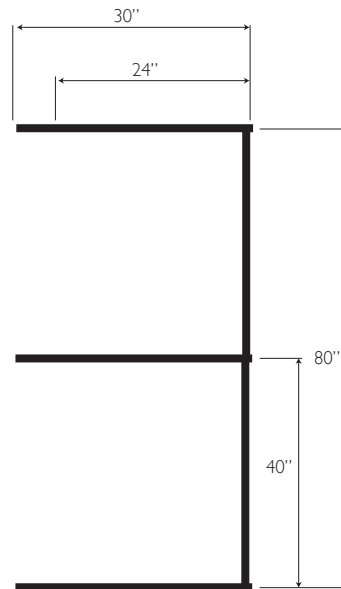

Double tier sofa display stand

291207



▲ sloped waterfall (chrome finish)



▲ sloped razor (black finish)



▲ straight waterfall (chrome finish)



▲ straight tube (chrome finish)  
available in 8", 12" and 15"

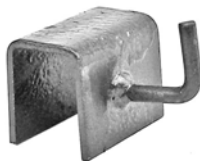

▲ hook hanger (black finish)



▲ straight bar (chrome finish)  
available in 8", 12" and 15"

# CLIPS and accessories



▲ standard clip (galvanised)



▲ plastic clip



▲ mini clip (galvanised)



▲ tiny clip (zinc plated)



▲ rubber clip cover

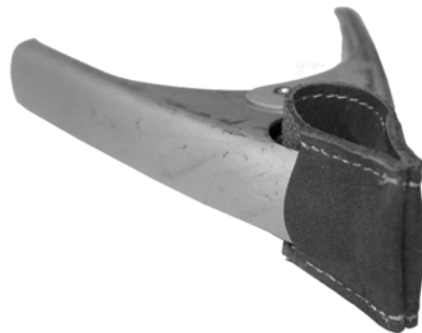

▲ leather clip cover

**▶ PRICES**

All our prices include 17.5% VAT. Delivery is extra, please contact us for a quote. We reserve the right to amend prices without prior notice.

**▶ PLACING YOUR ORDER**

You can place your order over the phone by calling our sales team on **01773 607505**.

**▶ PAYMENT**

We accept all major credit and debit cards, cheques (made payable to Gavin Kenning Engineering, please allow 5 working days to clear) or cash on collection.

**▶ DELIVERY**

Delivery is via a Next Day service. Due to the varying weights of the products we sell we advise that you to call prior to placing your order to obtain an accurate quote for delivery.

**▶ RETURNS**

Due to high transportation costs we only accept returns where the product is faulty or wrongly supplied. However, because we value our customers we are always prepared to consider individual cases.

---

**▶ STARTER KITS**

All our stalls can be purchased as a starter kit which includes a standard white cover, clips and 9mm plywood counters (where required).

**▶ BESPOKE DESIGNS**

If the stall you require is not featured in the brochure please contact us to discuss your requirements.

**▶ SPARE PARTS**

We also supply spare or replacement parts for all market stalls.

**▶ MATERIALS WE USE**

Our market stalls and accessories are manufactured using 25mm x 25mm (1" x 1") mild steel tube. Counters are made from 9mm plywood.

---

**▶ STALL HIRE**

We also hire market stalls to local authorities and organisations. Please contact us for further details.

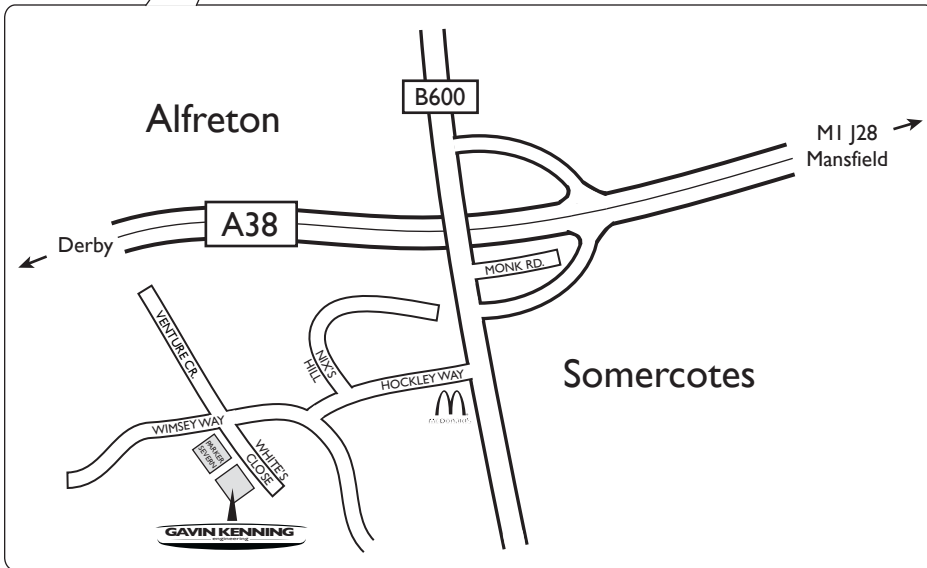
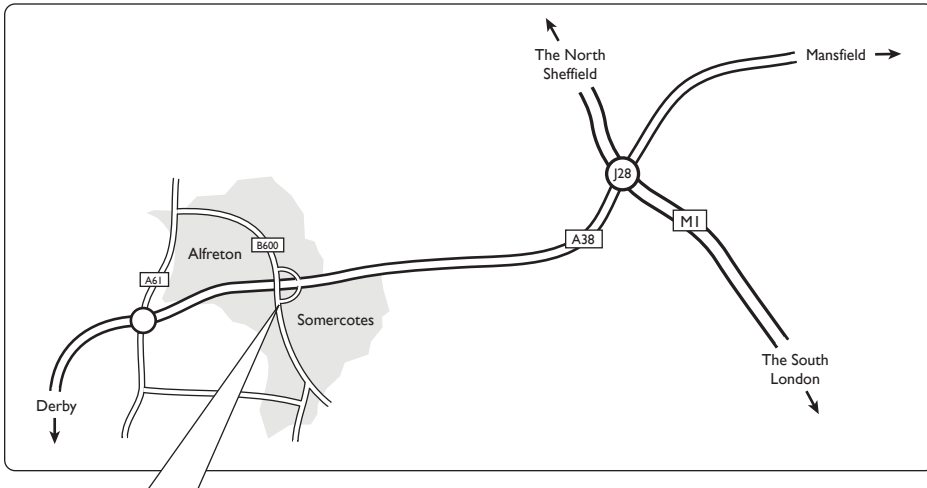

We're open **Monday to Friday** from **9:00am - 5:00pm** (opening hours may vary around public holidays — view our website for the latest information).  
No appointment is necessary. Ample car parking is provided for customers.  
Our premises offer disabled facilities.

Telephone: **01773 607505**  
Fax: **01773 540505**  
Website: **www.market-stalls.co.uk**  
Email: **sales@gavinkenningengineering.com**  
Address: **Gavin Kenning Engineering  
Whites Close  
Nix's Hill Industrial Estate  
Somercotes  
Derbyshire  
DE55 7RB**

We are situated in the East Midlands, 5 minutes from junction 28 of the M1, just 30 minutes from Nottingham, less than an hour from Sheffield, Leeds, Leicester and Birmingham and only 2 hours from London.

**DIRECTIONS FROM M1**

1. From J28 of the M1, follow the A38 westwards for approximately 2.5 miles.
  2. Exit at the second junction signposted Somercotes, B600 and Trading Estates.
  3. Turn left at the T-junction onto the B600 and take the first right onto Hockley Way (a McDonald's restaurant is situated on the corner).
  4. Follow Hockley Way down to another T-junction and turn right onto Wimsey Way.
  5. Follow the road around the bend and at the cross-roads turn left onto White's Close.
- Gavin Kenning Engineering is the second factory unit on the right, nextdoor to Parker Severn Builders Merchants.

**DIRECTIONS FROM A38 EAST**

1. From Derby, follow the A38 for approximately 15 miles.
  2. Pass under the junction signposted Matlock, Chesterfield and A61 and continue for another half mile before exiting at the junction signposted Somercotes, B600 and Trading Estates.
  3. Turn left at the T-junction onto the B600, continue over the A38 and take the first right onto Hockley Way (a McDonald's restaurant is situated on the corner).
  4. Follow Hockley Way down to another T-junction and turn right onto Wimsey Way.
  5. Follow the road around the bend and at the cross-roads turn left onto White's Close.
- Gavin Kenning Engineering is the second factory unit on the right.

291207